

**VOID**

Hear. Feel. Connect.

[voidacoustics.com](http://voidacoustics.com)



# Air Stream

Pioneering audio excellence

USER GUIDE V2.1

©2023 Void Acoustics Research Ltd.

This user guide is subject to change without notice.  
For the latest online version, visit: [www.voidacoustics.com](http://www.voidacoustics.com)

Void Acoustics and the Void logo are registered trademarks of Void Acoustics Research Ltd. in the United Kingdom, USA and other countries; all other Void trademarks are the property of Void Acoustics Research Ltd.

# Contents

<b>1</b>	<b>Safety and regulations</b>	<b>4</b>
1.1	Important safety instructions	4
1.2	Limitations	4
1.3	EC declaration of conformity	4
1.4	UKCA Conformity	4
1.5	Warranty Statement	4
1.6	WEEE directive	4
<b>2</b>	<b>Unpacking and Checking</b>	<b>5</b>
<b>3</b>	<b>About</b>	<b>6</b>
3.1	Welcome	6
3.2	Air Stream overview	6
3.3	Key features	6
3.4	Air Stream specifications	7
3.5	Air Stream dimensions	7
<b>4</b>	<b>Cable and wiring</b>	<b>8</b>
4.1	Electrical safety	8
4.2	Cable considerations for fixed installations	8
4.3	Air Stream wiring diagram	8
4.4	Bias D1/Q3/Q2 Phoenix wiring	9
4.5	Bias Q3/Q5 speakON™ wiring	9
<b>5</b>	<b>Mounting</b>	<b>10</b>
5.1	Installation safety	10
5.2	Pole mounting	11
<b>6</b>	<b>Service</b>	<b>12</b>
6.1	Return authorisation	12
6.2	Shipping and packing considerations	12
<b>7</b>	<b>Appendix</b>	<b>13</b>

# 1 Safety and Regulations

## 1.1 Important safety instructions



The lightning flash with an arrowhead symbol within an equilateral triangle is intended to alert the user to the presence of uninsulated "dangerous voltage" within the product's enclosure that may be of sufficient magnitude to constitute a risk of electric shock to persons.



The exclamation point within an equilateral triangle is intended to alert the user of the presence of important operating and maintenance (servicing) instructions in the literature accompanying the appliance.

## Safety instructions - read this first

1. Read these instructions.
2. Keep these instructions.
3. Heed all warnings.
4. Follow all instructions.
5. Do not use this apparatus near water.
6. Clean only with a dry cloth.
7. Do not block any ventilation openings. Install in accordance with the manufacturer's instructions.
8. Do not install near any heat source such as radiators, heat registers, stoves, or other such apparatus that produce heat.
9. Do not defeat the safety purpose of the grounding-type plug. A grounding type plug has two blades and a third grounding prong. The third prong is provided for your safety. If the provided plug does not fit into your outlet, consult an electrician for replacement of the obsolete outlet.
10. Protect power cords from being walked on or pinched particularly at plugs, convenience receptacles, and the point where they exit the apparatus.
11. Only use attachments and accessories specified by Void Acoustics.
12. Only use with the cart, stand, tripod, bracket, or table specified by the manufacturer, or sold with the apparatus. When a cart is used, use caution when moving the cart/apparatus combination to avoid injury from tip-over.
13. Unplug the apparatus during lightning storms or when unused for long periods of time.
14. Refer all servicing to qualified service personnel. Servicing is required when the apparatus has been damaged in any way, such as when the power-supply cord or plug is damaged, liquid has been spilled or objects have fallen into the apparatus, the apparatus has been exposed to rain or moisture, does not operate normally, or has been dropped.
15. Since the mains power supply cord attachment plug is used to disconnect the device, the plug should always be easily accessible.
16. Void loudspeakers can produce sound levels capable of causing permanent hearing damage from prolonged exposure. The higher the sound level, the less exposure needed to cause such damage. Avoid prolonged exposure to the high sound levels from the loudspeaker.

## 1.2 Limitations

This guide is provided to help familiarise the user with the loudspeaker system and its accessories. It is not intended to provide comprehensive electrical, fire, mechanical and noise training and is not a substitute for industry-approved training. Nor does this guide absolve the user of their obligation to comply with all relevant safety legislation and codes of practice. While every care has been taken in creating this guide, safety is user-dependent and Void Acoustics Research Ltd cannot guarantee complete safety whenever the system is rigged and operated.

## 1.3 EC declaration of conformity

For EC Declaration of Conformity please go to:

[www.voidacoustics.com/eu-declaration-loudspeakers](http://www.voidacoustics.com/eu-declaration-loudspeakers)

## 1.4 UKCA marking

For details of the UKCA marking go to:

[www.voidacoustics.com/uk-declaration-loudspeakers](http://www.voidacoustics.com/uk-declaration-loudspeakers)

## 1.5 Warranty statement

For warranty statement go to:

<https://voidacoustics.com/terms-conditions/>

## 1.6 WEEE directive

If the time arises to throw away your product, please recycle all the components possible.



This symbol indicates that when the end-user wishes to discard this product, it must be sent to separate collection facilities for recovery and recycling. By separating this product from other household-type waste, the volume of waste sent to incinerators or land-fills will be reduced and natural resources will thus be conserved.

The Waste Electrical and Electronic Equipment Directive (WEEE Directive) aims to minimise the impact of electrical and electronic goods on the environment. Void Acoustics Research Ltd complies with the Directive 2002/96/EC and 2003/108/EC of the European Parliament on waste electrical and electronic equipment (WEEE) in order to reduce the amount of WEEE that is being disposed of in land-fill sites. All of our products are marked with the WEEE symbol; this indicates that this product must NOT be disposed of with other waste. Instead it is the user's responsibility to dispose of their waste electrical and electronic equipment by handing it over to an approved reprocessor, or by returning it to Void Acoustics Research Ltd for reprocessing. For more information about where you can send your waste equipment for recycling, please contact Void Acoustics Research Ltd or one of your local distributors.

## 2 Unpacking and Checking

All Void Acoustics products are carefully manufactured and thoroughly tested before being despatched. Your dealer will ensure that your Void products are in pristine condition before being forwarded to you but mistakes and accidents can happen.

Before signing for your delivery:

- Inspect your shipment for any signs of contamination, abuse or transit damage as soon as you receive it
- Check your Void Acoustics delivery fully against your order
- If your shipment is incomplete or any of its contents are found to be damaged; inform the shipping company and inform your dealer.

When you are removing your Air Stream loudspeaker from its original packaging:

- Undo the four butterfly catches on the transport case then remove the lid making sure the lid is clear before moving sideways
- If you need to place the Air Stream loudspeaker on a flat surface ensure you use a lint free product to protect the finish
- When you have removed the Air Stream loudspeaker from the packaging inspect it to ensure there is no damage and keep all original packaging in case it needs to be returned for any reason.

See section 2 for warranty conditions and see section 6 if your product needs servicing.

# 3 About

## 3.1 Welcome

Many thanks for purchasing this Void Acoustics Air Stream. We truly appreciate your support. At Void, we design, manufacture and distribute advanced professional audio systems for the installed and live sound market sectors. Like all Void products, our highly skilled and experienced engineers have successfully combined pioneering technologies with ground-breaking design aesthetics, to bring you superior sound quality and visual innovation. In buying this product, you are now part of the Void family and we hope using it brings you years of satisfaction. This guide will help you both use this product safely and ensure it performs to its full capability.

## 3.2 Air Stream overview

Noteworthy DJs know the Air Stream is the ultimate three-way DJ monitor. Don't be fooled by its compact form which is capable of truly epic sound, equally suitable for all sized venues and EDM events.

## 3.3 Key features

- Specifically designed for DJ monitoring
- Point source radiation
- Optimised for near field applications
- Phase coherent behaviour
- Low resonance fibreglass composite construction
- Full range operational capabilities

# 3 About

## 3.4 Air Stream specifications

Frequency response	54 Hz - 20 kHz
Efficiency <sup>1</sup>	107 dB 1W/1m
Crossover point	1.6 kHz Passive
Nominal impedance	8 $\Omega$
Power handling <sup>2</sup>	LF: 700 W AES HF: 500 W AES
Maximum output <sup>3</sup>	127 dB cont, 133 dB peak
Driver configuration	LF: 1 x 15" MHF: 1 x 12" coax with 1.5" compression driver
Mounting	Pole mount
Dispersion	70°H x 45°V
Connectors	1 x 4 pole speakON™
Height	743.5 mm (29.3")
Width	511 mm (20.1")
Depth	499 mm (19.6")
Weight	42.5 kg (93.7 lbs)
Enclosure	Smooth cellulose

<sup>1</sup> Measured in half space <sup>2</sup> AES2 - 1984 compliant <sup>3</sup> Calculated

## 3.5 Air Stream dimensions

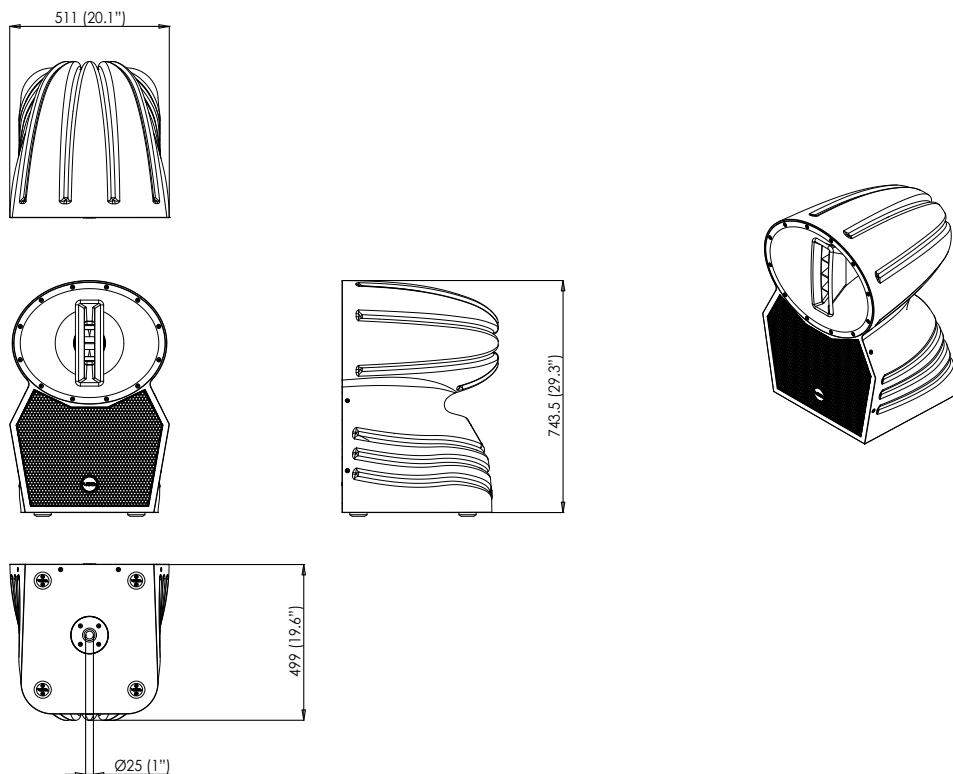

Figure 3.1: Dimensions

# 4 Cable and Wiring

## 4.1 Electrical safety



To avoid electrical hazards please note the following:

- Do not access the inside of any electrical equipment. Refer servicing to Void-approved service agents.

## 4.2 Cable considerations for fixed installations

We recommend specifying installation-grade Low Smoke Zero Halogen (LSZH) cables for permanent installations. The cables should use Oxygen Free Copper (OFC) of grade C11000 or above. Cables for permanent installations should be compliant with the following standards:

- IEC 60332.1 Fire retardancy of a single cable
- IEC 60332.3C Fire retardancy of bunched cables
- IEC 60754.1 Amount of Halogen Gas Emissions
- IEC 60754.2 Degree of acidity of released gases
- IEC 61034.2 Measurement of smoke density.

We suggest using the following maximum copper cable lengths to keep level losses below 0.6 dB.

Metric mm <sup>2</sup>	Imperial AWG	8 Ω load	4 Ω load
2.50 mm <sup>2</sup>	13 AWG	36 m	18 m
4.00 mm <sup>2</sup>	11 AWG	60 m	30 m

## 4.3 Air Stream wiring diagram

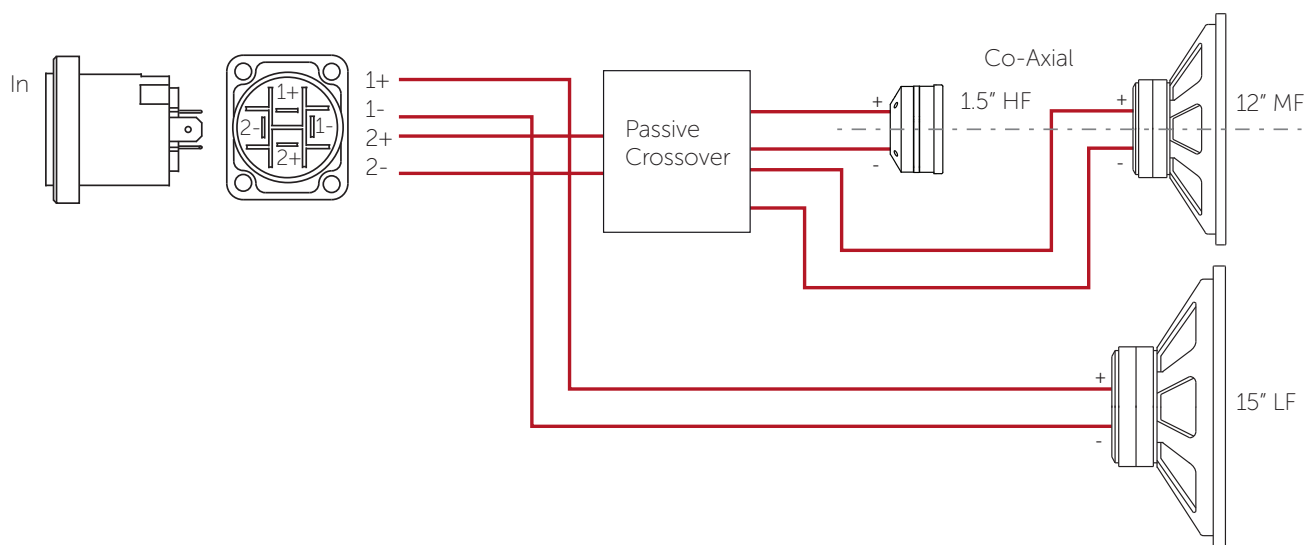

Figure 4.1: Wiring diagram

	speakON™ pins 1+/1-	speakON™ pins 2+/2-
In	LF (15")	MHF (12" + 1.5")



# 4 Cable and Wiring

## 4.4 Bias D1/Q1/Q2 Phoenix wiring

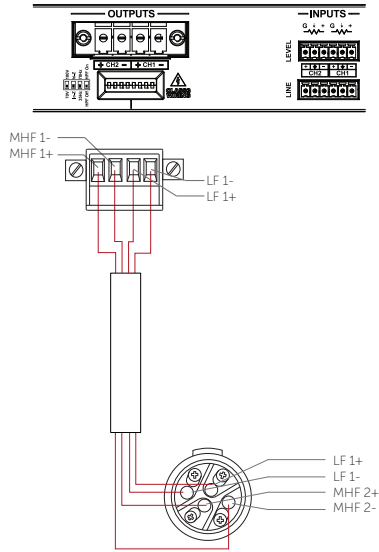

Figure 4.2: Bias D1

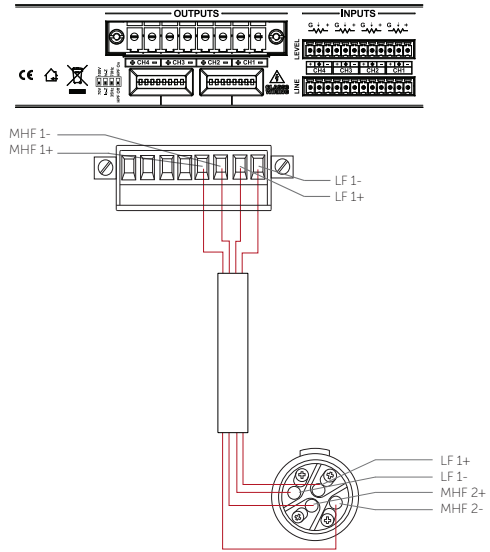

Figure 4.3: Bias Q1/Q2

Bias D1/Q1/Q2	Output 1	Output 2
Output	LF (15")	MHF (12"+1.5")

## 4.5 Bias Q3/Q5 speakON™ wiring

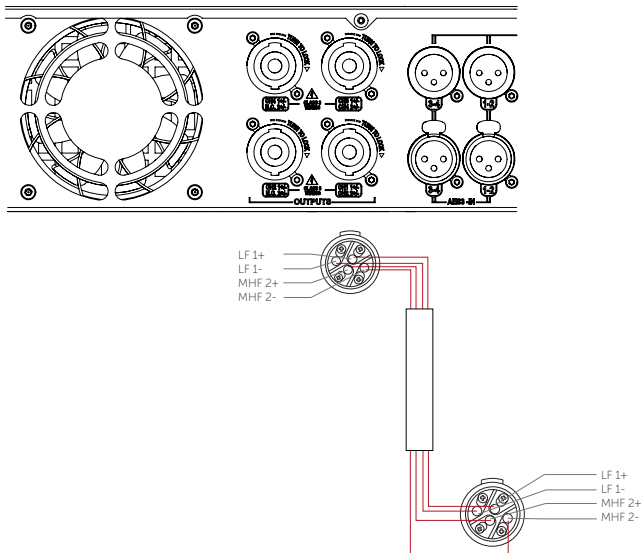

Figure 4.4: Bias Q3

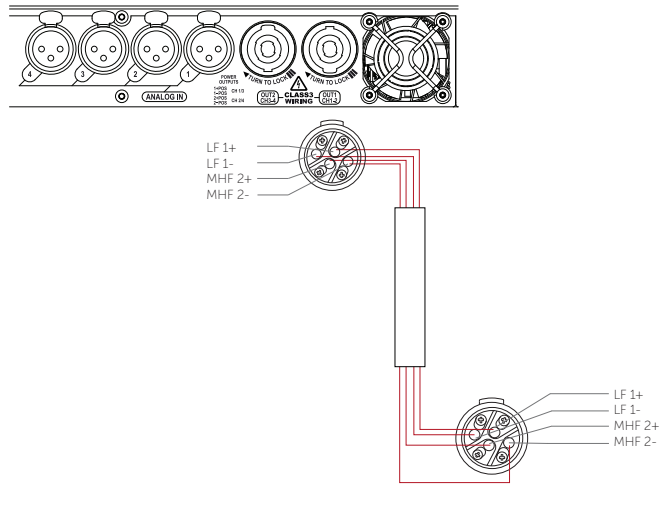

Figure 4.5: Bias Q5

Bias Q5	Output 1	Output 2
Output	LF (15")	MHF (12"+1.5")

# 5 Mounting

## 5.1 Installation safety



To avoid mechanical hazards, please note the following:

- Safety regulations vary in different regions. Full compliance with those regulations must be your priority
- Installations must only be undertaken by fully qualified and experienced engineers/technicians who understand local regulations
- This may include consulting a structural engineer before installation of wall brackets
- Remember that all personnel have a duty of care to themselves, to their assistants, to the venue staff and to the public
- Before lifting any part of the system above head height, check the whole rig for loose tools or other items that may fall and cause injury
- Do not use a telephone (even if hands-free) whilst installing. Always concentrate fully on the installation operation
- Do not install equipment that is worn, damaged, corroded, mishandled or overstressed in any way
- Use only Void-approved mounting equipment and accessories
- Secondary safeties should be provided in all instances where cabinets are flying or fixing overhead and should conform to local regulations

## 5.2 Pole Mounting

Parts required:

- 35 mm pole



Figure 5.1: 35 mm pole

### Step 1:

Once the pole has been fitted to an appropriate mount raise the Air Stream loudspeaker into position.

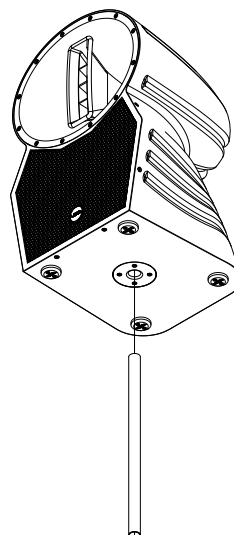

Figure 5.2: Loudspeaker positioning

### Step 2:

Mount the Air Stream loudspeaker on the pole and rotate to the desired position.

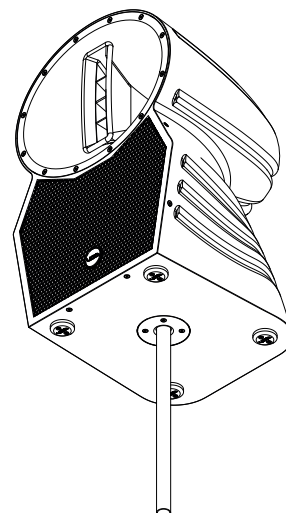

Figure 5.3: Loudspeaker positioning

# 6 Service

Void Air Stream loudspeakers should only be serviced by a fully-trained technician.



No user serviceable parts inside. Refer servicing to your dealer.

## 6.1 Return authorisation

Before returning your faulty product for repair, please remember to get an R.A.N. (Return Authorisation Number) from the Void dealer who supplied the system to you. Your dealer will handle the necessary paperwork and repair. Failure to go through this return authorisation procedure could delay the repair of your product.

Note that your dealer will need to see a copy of your sales receipt as proof of purchase so please have this to hand when applying for return authorisation.

## 6.2 Shipping and packing considerations

- When sending a Void Air Stream loudspeaker to an authorised service centre, please write a detailed description of the fault and list any other equipment used in conjunction with the faulty product.
- Accessories will not be required. Do not send the instruction manual, cables or any other hardware unless your dealer asks you to.
- Pack your unit in the original factory packaging if possible. Include a note of the fault description with the product. Do not send it separately.
- Ensure safe transportation of your unit to the authorised service centre.

# 7 Appendix

## Architectural specifications

The loudspeaker shall be an active, three-way, bi-amped system consisting of a high power 15" (381 mm) direct radiating reflex loaded Low frequency (LF) transducer with a passive two way mid-high frequency section consisting of a 12" (305 mm) horn loaded mid frequency (MF) transducer and a 1.5" (38.1mm) diameter exit, coaxial high frequency (HF) compression driver mounted on a user rotatable waveguide, in an aesthetic designed enclosure.

The LF and MF transducers shall be constructed on a cast aluminium frame, with a treated paper cone, 63.5 mm (4") for the LF and 50.8 mm (2") for the MF voice coil, wound with copper wires on a high quality voice coil former for high power handling and long-term reliability. The HF transducer shall project it's sound through a user rotatable waveguide with a 200 mm (8") baffle diameter.

Performance specifications for a typical production unit shall be as follows: the usable on-axis bandwidth shall be 54 Hz to 20 kHz ( $\pm 3$  dB) and shall average 45° directivity pattern on the vertical axis and 70° on the horizontal one (-6 dB down from on-axis level). Maximum SPL shall be 133 dB peak (127 dB continuous) measured at 1m using IEC268-5 pink noise. Power handling shall be 700 W AES for the LF at a rated impedance of 8  $\Omega$  and 500 W AES for the MHF at a rated impedance of 8  $\Omega$ . The system shall be powered by its own dedicated power amplification module with DSP management. The wiring connection shall be via one Neutrik speakON™ NL4.

The enclosure shall be of a special fibreglass composite with a smooth cellulose finish of any RAL colour. It shall contain fixture points for a pressed, weather-resistant, steel powder-coated grille with foam filter to protect the low frequency transducer. The system shall be stack mounted or can also be flown with a dedicated bracket. (W) 511 mm x (H) 743.5 mm x (D) 499 mm (20.1" x 29.3" x 19.6"). Weight shall be 42.5 kg (93.7 lbs).

The loudspeaker shall be the Void Acoustics Air Stream.

## NORTH AMERICA

Void Acoustics North America

**Call:** +1 630 686 6616

**Email:** [sales.usa@voidacoustics.com](mailto:sales.usa@voidacoustics.com)

## HEAD OFFICE

Void Acoustics Research Ltd,  
Unit 15, Dawkins Road Industrial Estate,  
Poole, Dorset,  
BH15 4JY  
United Kingdom

**Call:** +44(0) 1202 666006

**Email:** [info@voidacoustics.com](mailto:info@voidacoustics.com)



Hear. Feel. Connect.

[voidacoustics.com](http://voidacoustics.com)