

VOID

Hear. Feel. Connect.

voidacoustics.com

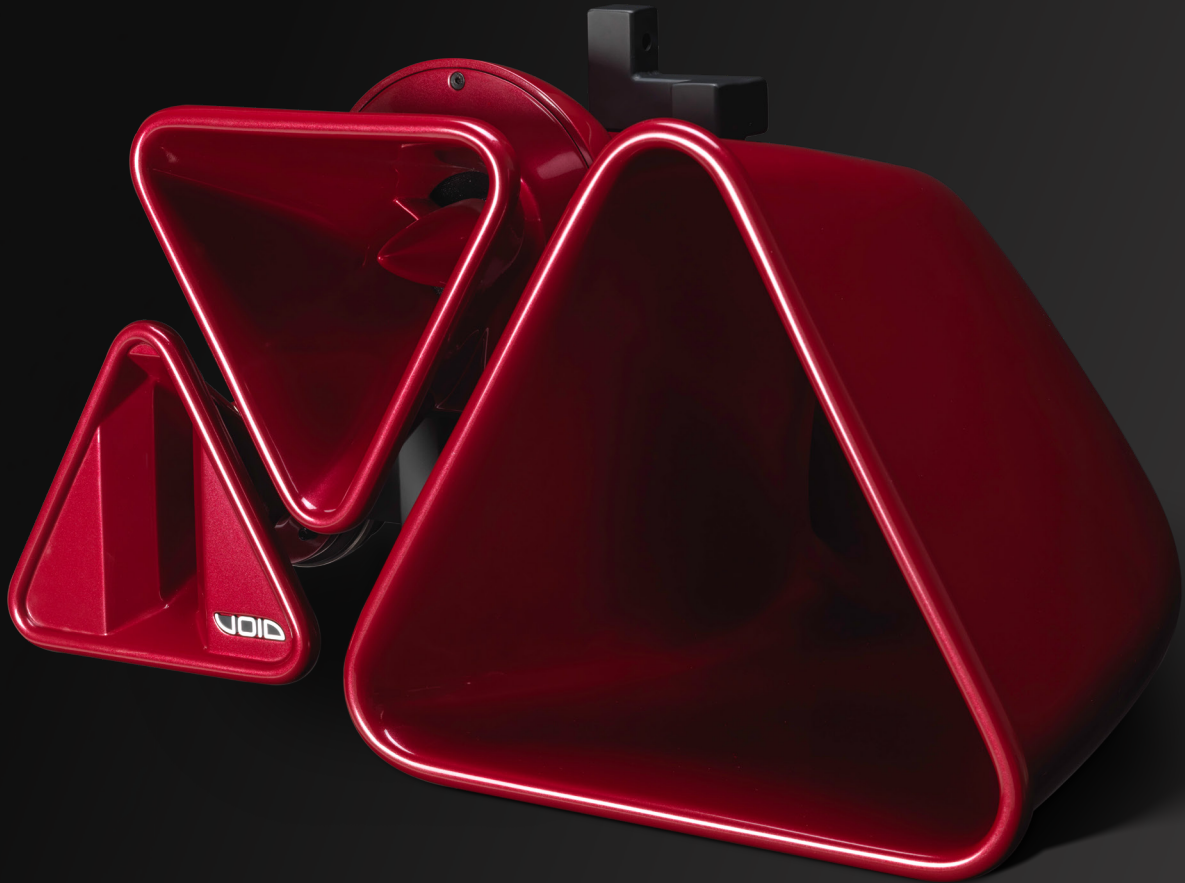

Tri Motion

Unrivalled composition, revolutionary sound

USER GUIDE V3.0

©2022 Void Acoustics Research Ltd.

This user guide is subject to change without notice.
For the latest online version, visit: www.voidacoustics.com

Void Acoustics and the Void logo are registered trademarks of Void Acoustics Research Ltd. in the United Kingdom, USA and other countries; all other Void trademarks are the property of Void Acoustics Research Ltd.

Contents

1	Safety and regulations	4
1.1	Important safety instructions	4
1.2	Limitations	4
1.3	EC declaration of conformity	4
1.4	UKCA Conformity	4
1.5	Warranty Statement	4
1.6	WEEE directive	4
2	Unpacking and Checking	5
3	About	6
3.1	Welcome	6
3.2	Tri Motion overview	6
3.3	Key features	6
3.4	Tri Motion specifications	7
3.5	Tri Motion dimensions	8
4	Cable and wiring	9
4.1	Electrical safety	9
4.2	Cable considerations for fixed installations	9
4.3	Tri Motion wiring diagram	10
4.4	Bias D1/Q1/Q2 phoenix wiring	11
4.5	Bias Q3/Q5 speakON™ wiring	11
5	Mounting	12
5.1	Installation safety	12
5.2	Mounting the 'U' bracket	13
5.3	Wall mounting	14
5.4	Ground stack	17
5.5	Ceiling mounting	19
5.6	Truss mounting	20
5.7	Ceiling pole mounting	22
5.8	Pole mounting	23
6	Service	25
7	Appendix	26

1 Safety and Regulations

1.1 Important safety instructions



The lightning flash with an arrowhead symbol within an equilateral triangle is intended to alert the user to the presence of uninsulated "dangerous voltage" within the product's enclosure that may be of sufficient magnitude to constitute a risk of electric shock to persons.



The exclamation point within an equilateral triangle is intended to alert the user of the presence of important operating and maintenance (servicing) instructions in the literature accompanying the appliance.

Safety instructions - read this first

1. Read these instructions.
2. Keep these instructions.
3. Heed all warnings.
4. Follow all instructions.
5. Do not use this apparatus near water.
6. Clean only with a dry cloth.
7. Do not block any ventilation openings. Install in accordance with the manufacturer's instructions.
8. Do not install near any heat source such as radiators, heat registers, stoves, or other such apparatus that produce heat.
9. Do not defeat the safety purpose of the grounding-type plug. A grounding type plug has two blades and a third grounding prong. The third prong is provided for your safety. If the provided plug does not fit into your outlet, consult an electrician for replacement of the obsolete outlet.
10. Protect power cords from being walked on or pinched particularly at plugs, convenience receptacles, and the point where they exit the apparatus.
11. Only use attachments and accessories specified by Void Acoustics.
12. Only use with the cart, stand, tripod, bracket, or table specified by the manufacturer, or sold with the apparatus. When a cart is used, use caution when moving the cart/apparatus combination to avoid injury from tip-over.
13. Unplug the apparatus during lightning storms or when unused for long periods of time.
14. Refer all servicing to qualified service personnel. Servicing is required when the apparatus has been damaged in any way, such as when the power-supply cord or plug is damaged, liquid has been spilled or objects have fallen into the apparatus, the apparatus has been exposed to rain or moisture, does not operate normally, or has been dropped.
15. Since the mains power supply cord attachment plug is used to disconnect the device, the plug should always be easily accessible.
16. Void loudspeakers can produce sound levels capable of causing permanent hearing damage from prolonged exposure. The higher the sound level, the less exposure needed to cause such damage. Avoid prolonged exposure to the high sound levels from the loudspeaker.

1.2 Limitations

This guide is provided to help familiarise the user with the loudspeaker system and its accessories. It is not intended to provide comprehensive electrical, fire, mechanical and noise training and is not a substitute for industry-approved training. Nor does this guide absolve the user of their obligation to comply with all relevant safety legislation and codes of practice. While every care has been taken in creating this guide, safety is user-dependent and Void Acoustics Research Ltd cannot guarantee complete safety whenever the system is rigged and operated.

1.3 EC declaration of conformity

For EC Declaration of Conformity please go to:

www.voidacoustics.com/eu-declaration-loudspeakers

1.4 UKCA marking

For details of the UKCA marking go to:

www.voidacoustics.com/uk-declaration-loudspeakers

1.5 Warranty statement

For warranty statement go to:

<https://voidacoustics.com/terms-conditions/>

1.6 WEEE directive

If the time arises to throw away your product, please recycle all the components possible.



This symbol indicates that when the end-user wishes to discard this product, it must be sent to separate collection facilities for recovery and recycling. By separating this product from other household-type waste, the volume of waste sent to incinerators or land-fills will be reduced and natural resources will thus be conserved.

The Waste Electrical and Electronic Equipment Directive (WEEE Directive) aims to minimise the impact of electrical and electronic goods on the environment. Void Acoustics Research Ltd complies with the Directive 2002/96/EC and 2003/108/EC of the European Parliament on waste electrical and electronic equipment (WEEE) in order to reduce the amount of WEEE that is being disposed of in land-fill sites. All of our products are marked with the WEEE symbol; this indicates that this product must NOT be disposed of with other waste. Instead it is the user's responsibility to dispose of their waste electrical and electronic equipment by handing it over to an approved reprocessor, or by returning it to Void Acoustics Research Ltd for reprocessing. For more information about where you can send your waste equipment for recycling, please contact Void Acoustics Research Ltd or one of your local distributors.

2 Unpacking and Checking

All Void Acoustics products are carefully manufactured and thoroughly tested before being despatched. Your dealer will ensure that your Void products are in pristine condition before being forwarded to you but mistakes and accidents can happen.

Before signing for your delivery:

- Inspect your shipment for any signs of contamination, abuse or transit damage as soon as you receive it
- Check your Void Acoustics delivery fully against your order
- If your shipment is incomplete or any of its contents are found to be damaged; inform the shipping company and inform your dealer.

Tri Motion loudspeakers are heavy (47.1 kg/103.8 lbs) and require a minimum two people to lift.

- Undo the four butterfly catches on the transport case then remove the lid making sure the lid is clear before moving sideways
- If you need to place the Tri Motion on a flat surface ensure you use a lint free product to protect the finish
- To remove from the transport case, each person should hold the Tri Motion on each side, with one hand on the edge of the horn flare, and the other supporting the weight of the drivers to the rear, as shown in figure 2.1
- When removing the Tri Motion take care not to damage the lower tray of the transport case.

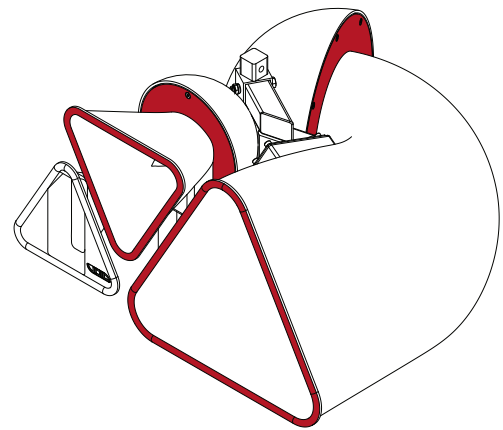

Figure 2.1: Safe handling positions diagram (as indicated in red)

Keep the original packaging in case you need to return a product for service later.

See section 1.5 for warranty conditions and see section 6 if your product needs servicing.

3 About

3.1 Welcome

Many thanks for purchasing this Void Acoustics Tri Motion. We truly appreciate your support. At Void, we design, manufacture and distribute advanced professional audio systems for the installed and live sound market sectors. Like all Void products, our highly skilled and experienced engineers have successfully combined pioneering technologies with ground-breaking design aesthetics, to bring you superior sound quality and visual innovation. In buying this product, you are now part of the Void family and we hope using it brings you years of satisfaction. This guide will help you both use this product safely and ensure it performs to its full capability.

3.2 Tri Motion overview

The aesthetically striking Tri Motion pushes sonic and creative frontiers, providing extraordinary efficiency and controlled dispersion, perfect for larger venues requiring cutting-edge performance.

3.3 Key Features

- Triangular format waveguides for enhanced pattern control
- Low resonance fibreglass composite construction
- Integrated flying and mounting system
- Optional floor stand or flying bracket

3 About

3.4 Tri Motion specifications

Frequency response	120 Hz - 20 kHz \pm 3 dB
Efficiency	LF: 107 dB 1W/1m, HMF: 110 dB 1W/1m
Nominal impedance	LF: 8 Ω , HMF: 8 Ω
Power handling ¹	LF: 700 W AES, HMF: 250 W AES
Maximum output ²	135 dB cont, 141 dB peak
Driver configuration	1 x 15" LF, 1 x 8" MF, 1 x 1.5" HF compression driver
Dispersion	90°H x 60°V
Connectors	2 x 4-pole speakON™ NL4
Height	515 mm (20.3")
Width	810 mm (31.9")
Depth	720 mm (28.3")
Weight	47.1 kg (103.8 lbs)
Enclosure	Fibreglass composite
Mounting	Internal fly/mounting system. Can be used with stand or bracket
Colour	Custom colours available upon request

¹ AES2 - 1984 compliant ² Calculated

3 About

3.5 Tri Motion dimensions

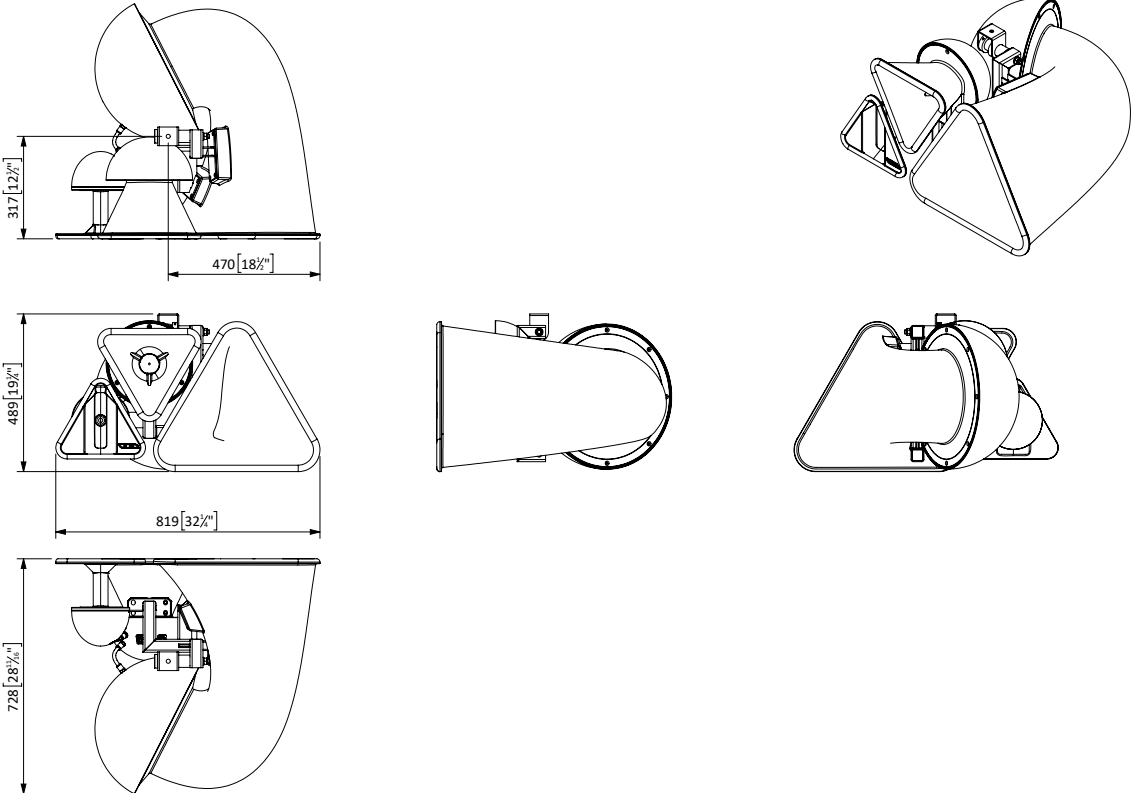

Figure 3.1: Dimensions (left-handed version)

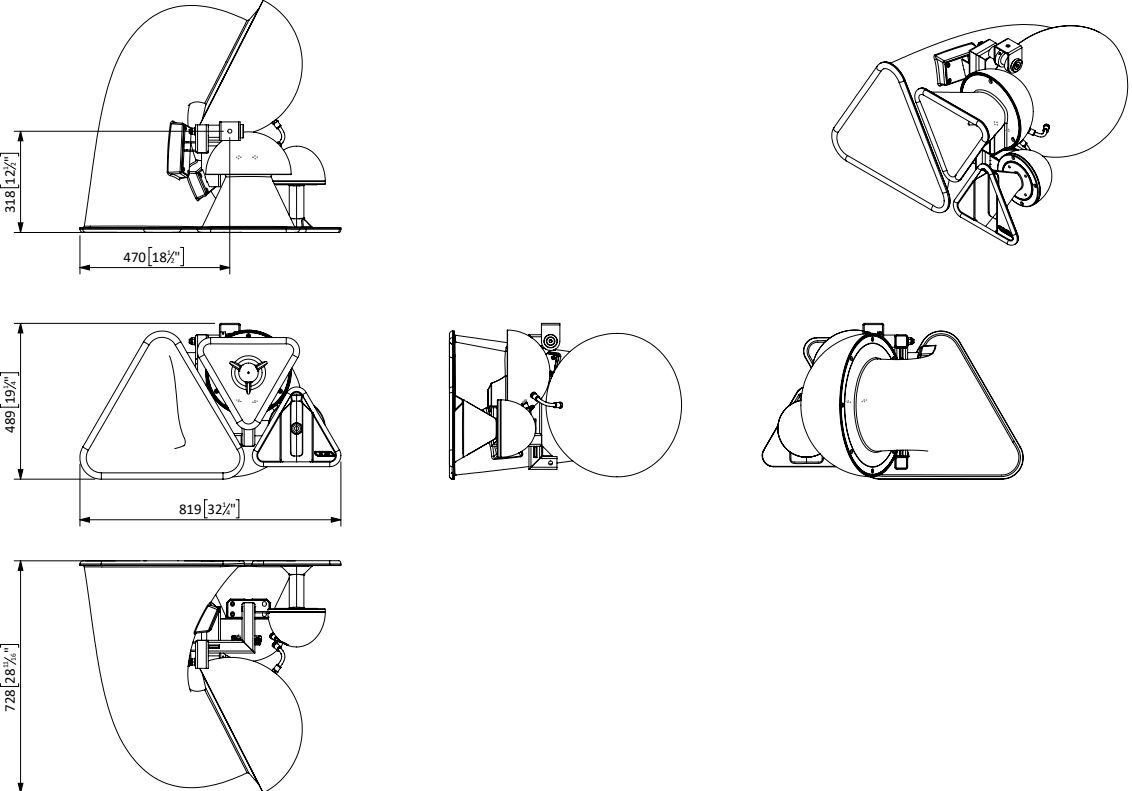

Figure 3.2: Dimensions (right-handed version)

4 Cable and Wiring

4.1 Electrical safety



To avoid electrical hazards please note the following:

- Do not access the inside of any electrical equipment. Refer servicing to Void-approved service agents

4.2 Cable considerations for fixed installations

We recommend specifying installation-grade Low Smoke Zero Halogen (LSZH) cables for permanent installations. Cables for permanent installations should be compliant with the following standards:

- IEC 60332.1 Fire retardancy of a single cable
- IEC 60332.3C Fire retardancy of bunched cables
- IEC 60754.1 Amount of Halogen Gas Emissions
- IEC 60754.2 Degree of acidity of released gases
- IEC 61034.2 Measurement of smoke density

Tri Motion loudspeakers are 3-way, bi-amplified. They require two amplifier channels to drive them via 4-core speakON™ NL4 cables. We suggest using the following maximum copper cable lengths to keep level losses below 0.6 dB.

Metric mm ²	Imperial AWG	8 Ω load	4 Ω load	2 Ω load
2.50 mm ²	13 AWG	36 m	18 m	9 m
4.00 mm ²	11 AWG	60 m	30 m	15 m

4 Cable and Wiring

4.3 Tri Motion wiring diagram

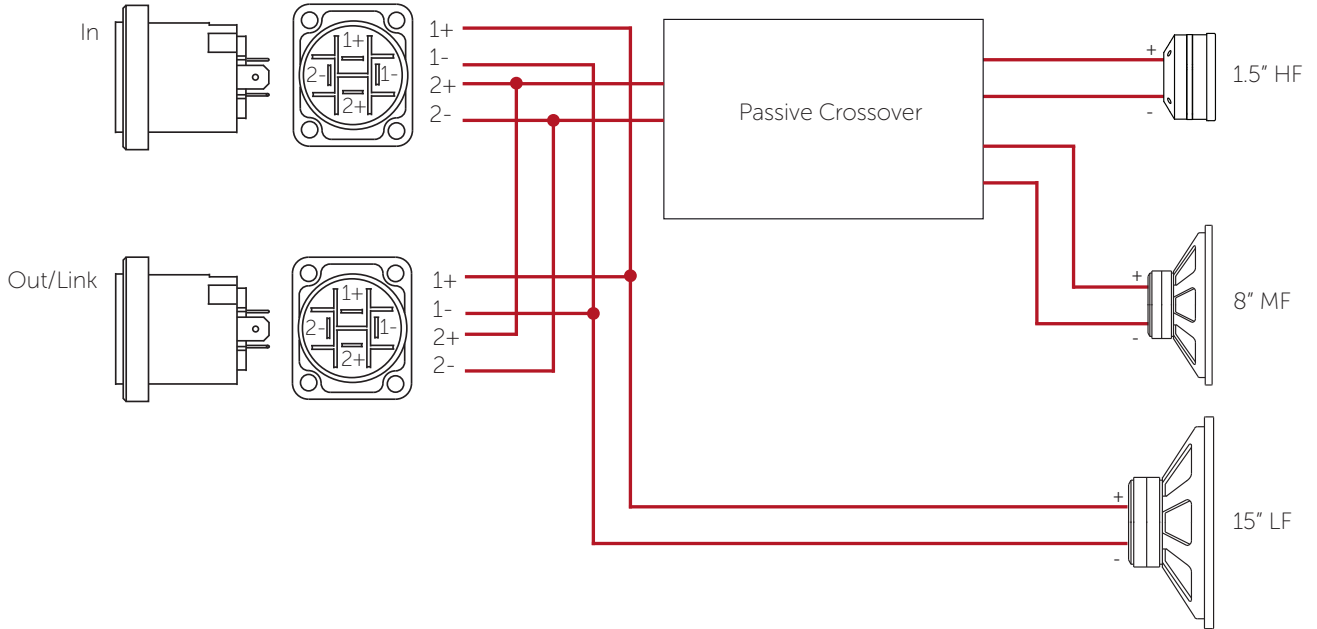

Figure 4.1: Tri Motion wiring diagram

	speakON™ pins 1+/1-	speakON™ pins 2+/2-
In	LF (15")	MHF (8" + 1.5")
Out	LF link	MHF link

4 Cable and Wiring

4.4 Bias D1/Q1/Q2 phoenix wiring

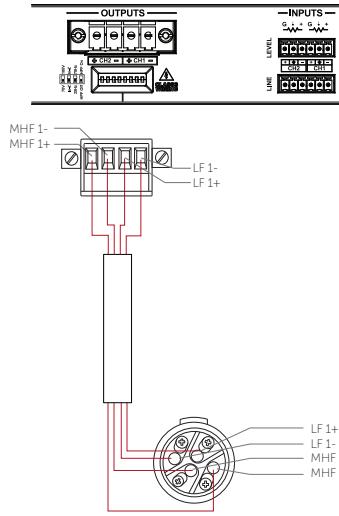

Figure 4.2: Bias D1

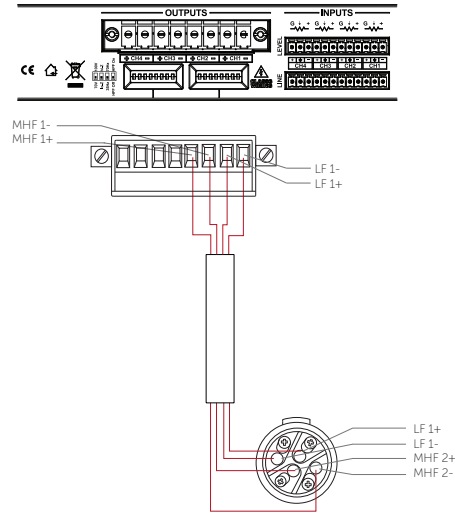

Figure 4.3: Bias Q1/Q2

Bias D1/Q1/Q2	Output 1	Output 2
Output	LF (15")	MHF (8"+1.5")
Max parallel units	4 (2 Ω load to amplifier)*	4 (2 Ω load to amplifier)*

*Recommended max parallel units 2 (4 Ω load to amplifier) due to the power rating of the amplifier.

4.5 Bias Q3/Q5 speakON™ wiring

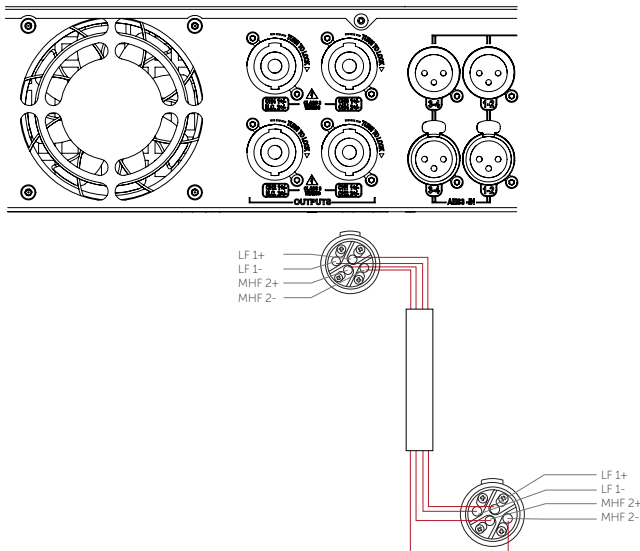

Figure 4.4: Bias Q3

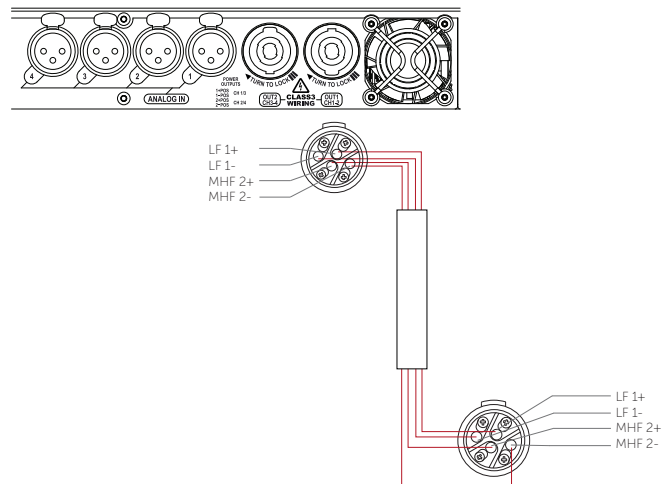

Figure 4.5: Bias Q5

Bias Q3/Q5	Output 1	Output 2
Output	LF (15")	MHF (8"+1.5")
Max quantity per channel	2 (4 Ω load to amplifier)	2 (4 Ω load to amplifier)

5 Mounting

Tools required

- 19 mm ratchet spanner/wrench
- 6 mm Allen key

5.1 Installation safety



To avoid mechanical hazards, please note the following:

- Safety regulations vary in different regions. Full compliance with those regulations must be your priority
- Rigging must only be undertaken by fully-qualified and experienced riggers who understand local regulations
- This may include consulting a structural engineer before installation of wall brackets
- Remember that all personnel have a duty of care to themselves, to their assistants, to the venue staff and to the public
- Before lifting any part of the system above head height, check the whole rig for loose tools or other items that may fall and cause injury
- Do not use a telephone (even if hands-free) while rigging. Always concentrate fully on the rigging operation
- Do not rig equipment that is worn, damaged, corroded, mishandled or over-stressed in any way
- Use only Void-approved mounting equipment and accessories
- Secondary safeties should be provided in all instances where cabinets are flying or fixing overhead and should conform to local regulations

5.2 Mounting the 'U' Bracket

When preparing to deploy the Tri Motion the 'U' bracket assembly must be positioned for ground stack or flying configuration.

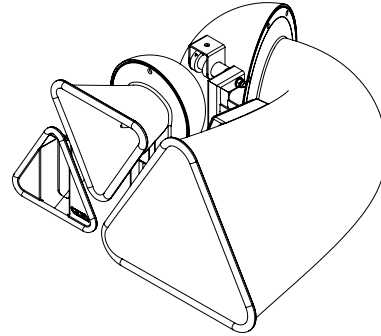

Figure 5.1: 'U' bracket assembly in flying configuration

Step 1:

All Tri Motion have the 'U' bracket assembly fitted in the flying configuration for shipping. To change to a ground stack configuration first remove the M12 nut and washer from the assembly removing it from the main internal bracket assembly.

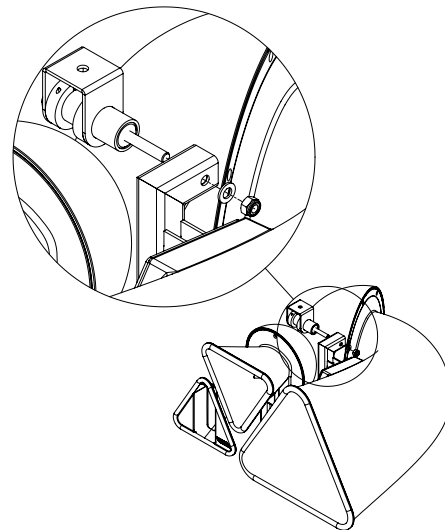

Figure 5.2: 'U' bracket assembly removal

Step 2:

Align the bracket assembly with the hole in the bottom of the main internal bracket assembly and fasten with the M12 nut and washer.

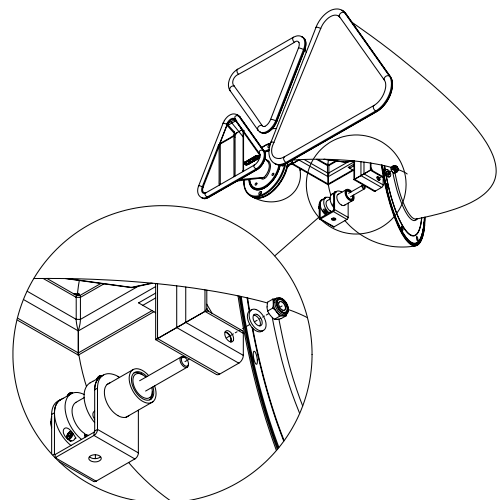

Figure 5.3: 'U' bracket assembly in ground stack configuration

5.3 Wall Mounting

Parts required:

Multi Bracket Extension	White - IT2088
	Black - IT2089
TU - Multi Bracket (600mm)	White - IT1089
	Black - IT1088

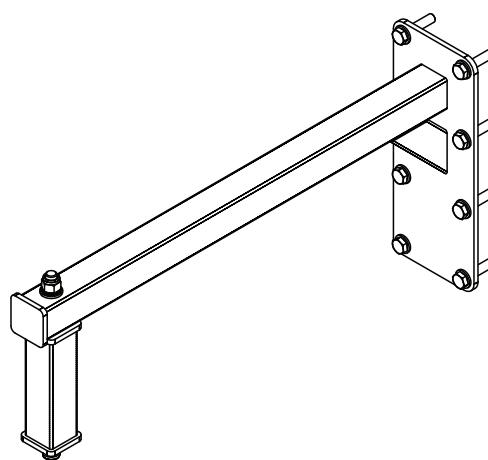

Figure 5.4: TU - Multi Bracket (600mm) with extension piece

Step 1:

Begin by fixing the bracket to the wall and then fix the extension piece to the bracket with the M12 Nyloc nut using a 19 mm ratchet spanner.



All eight bolts must be fitted when securing the bracket to the wall. Take care when mounting the bracket to the wall, making sure to use the correct fixing and that the wall can take the load.

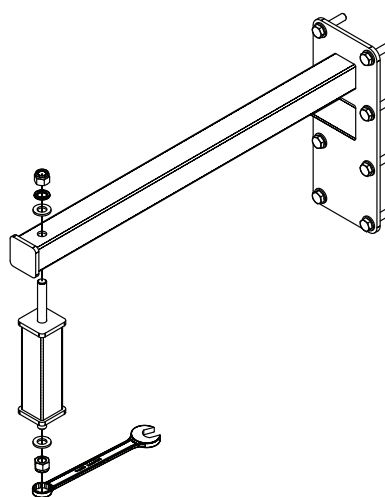

Figure 5.5: Extension piece assembly

Step 2:

Loosen but do not remove all four M5 bolts from the 'U' bracket assembly on the Tri Motion bracket.

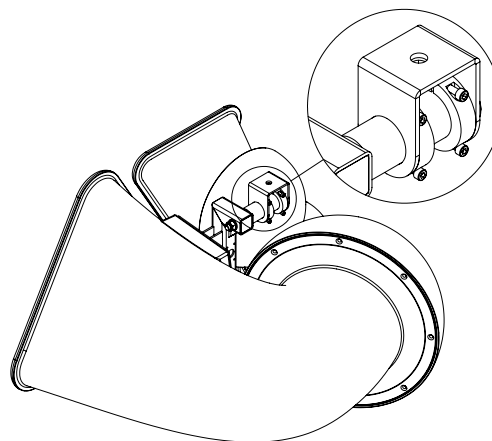

Figure 5.6: 'U' bracket assembly

5.3 Wall Mounting

Step 3:

Remove the M12 bolt and end cap from the end of the bracket assembly

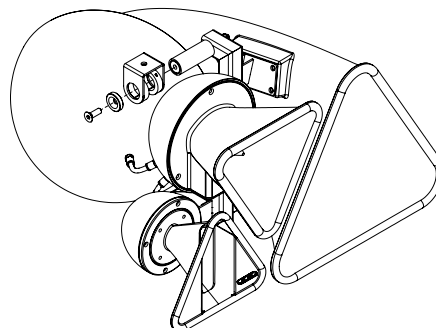

Figure 5.7: Removing the 'U' bracket

Step 4:

Attach the 'U' bracket assembly to the extension piece with the M12 nut and washer provided with the bracket

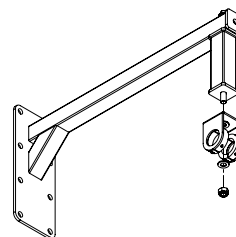

Figure 5.8: Attaching 'U' bracket to extension piece

Step 5:

Lift the Tri Motion into position and slide the main bracket assembly into the 'U' bracket assembly.

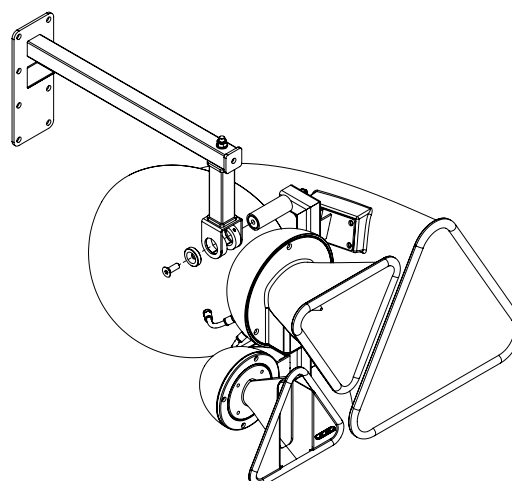

Figure 5.9: Tri Motion positioning

5.3 Wall Mounting

Step 6:

With the lifting gear still in position adjust the position of the Tri Motion left and right to ensure that it is level then rotate to the desired angle. Once the loudspeaker is in the desired position tighten all four M5 bolts on the 'U' bracket assembly.

Maximum vertical rotation: $+40^{\circ}, -45^{\circ}$

Maximum horizontal rotation: $\pm 180^{\circ}$

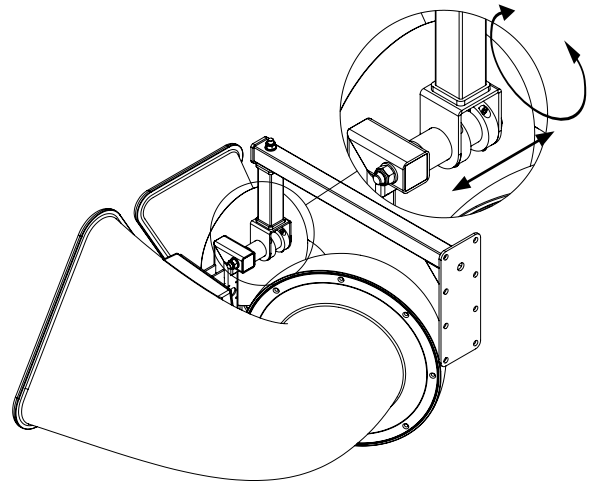

Figure 5.10: Tri Motion positioning

5.4 Ground Stack

Parts required:

Stasys X V2/Xair Mounting Board	White - IT1592
	Black - IT1591
TU - Multi Bracket (600mm)	White - IT1089
	Black - IT1088

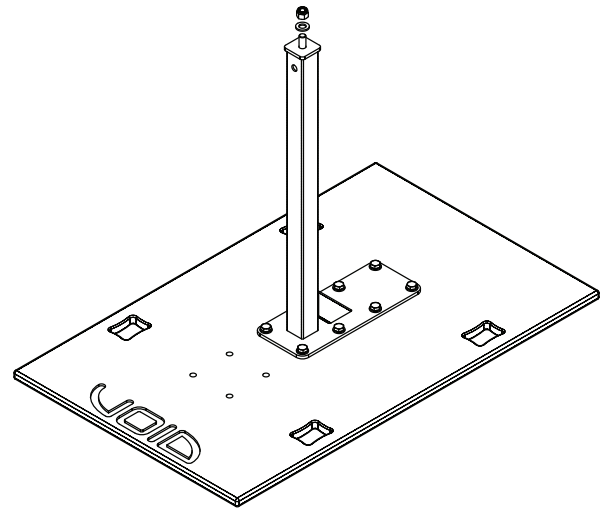

Figure 5.11: Stasys Xair/XV2 mounting board with TU - Multi Bracket

Step 1:
Remove M12 Nyloc nut from stand using 19 mm ratchet spanner.

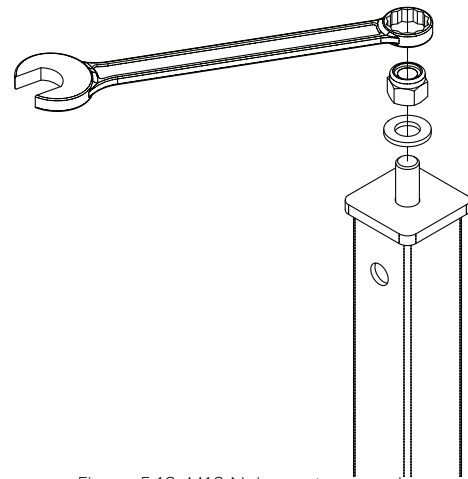

Figure 5.12: M12 Nyloc nut removal

Step 2:
Following the steps in section 5.2 to attach the 'U' bracket in the ground stack configuration. Remove the 'U' bracket assembly as described in section 5.3 and attach the assembly the mounting board as shown in figure 5.13.

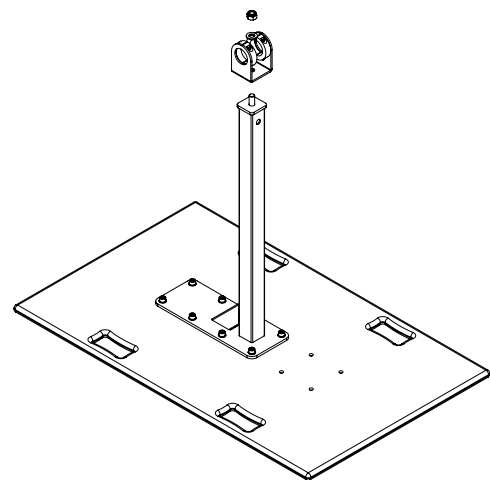

Figure 5.13: Attaching the 'U' bracket

5.4 Ground Stack



Step 3:

Lift the Tri Motion with two people (with one hand on the edge of the horn flare and the other supporting the weight of the drivers at the rear) and position the mounting hole over the stand bolt. For safe handling locations see section 2. Once in position adjust the position then tighten the M5 bolts as shown in figure 5:10.

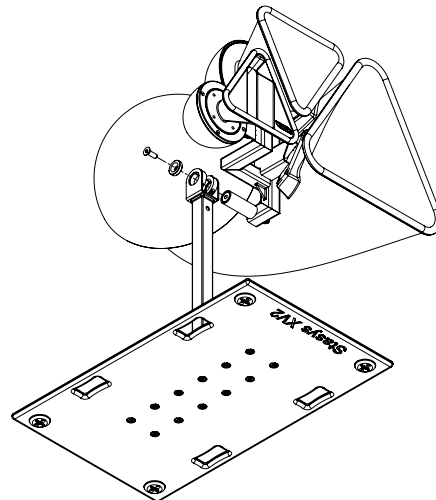

Figure 5.14: Mounting the loudspeaker

Step 4:

Confirm the Tri Motion is securely fastened to the stand, and lift the assembly onto the bass-cabinet with suitable equipment.



The assembly is heavy; be aware of the high centre of gravity! You will need to tilt the mounting board forward to place one hand under the board and get a secure grip on the hand hold. Then place your other hand on the horn-flare. Raise the assembly to the bass cabinet and slide until the feet drop into the feet pockets. If the bass cabinet is on an uneven surface, ensure that it is stabilised with wedges before mounting the Tri Motion.

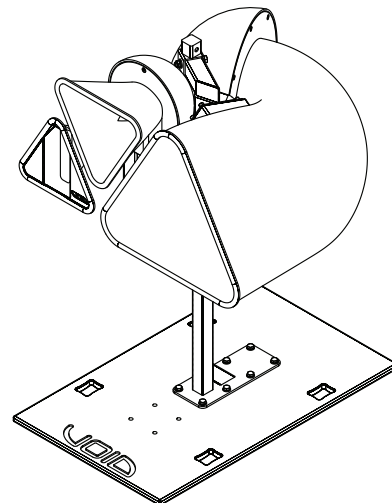

Figure 5.15: Tri Motion on mounting board

Step 5:

Secure with a minimum of one 1 tonne SWL ratchet straps. Ensure the stand is secured from sliding or rotating and on a level surface.

Maximum vertical rotation: $+86^{\circ}, -46^{\circ}$

Maximum horizontal rotation: $\pm 180^{\circ}$

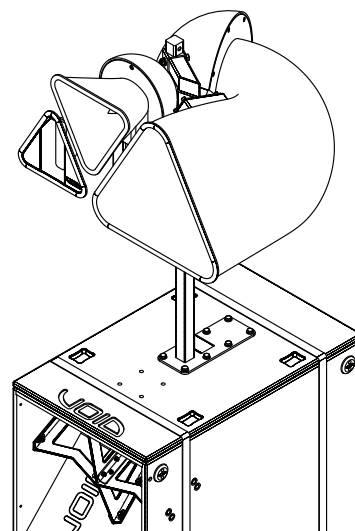

Figure 5.16: Tri Motion mounting

5.5 Ceiling Mounting

Parts required:

TU - Multi Bracket (600mm)	White - IT1089
	Black - IT1088

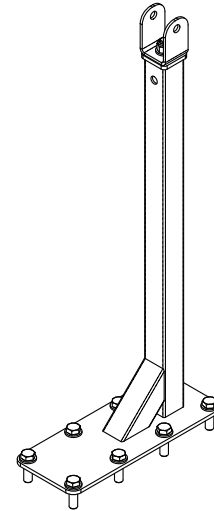

Figure 5.17: TU - Multi Bracket (600 mm)

Step 1:

Remove the 'U' bracket assembly as described in section 5.3 and attach it to the multi bracket as shown in figure 5.18



All eight bolts must be fitted when securing the bracket to the ceiling.

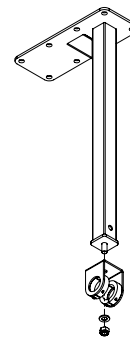

Figure 5.18: Attach 'U' bracket to multi bracket



Step 2:

Lift the Tri Motion with two people (with one hand on the edge of the horn flare and the other supporting the weight of the drivers at the rear) and position the mounting hole over the stand bolt. For safe handling locations see section 2. Once in position adjust the position then tighten the M5 bolts as shown in figure 5:10.

Maximum vertical rotation: +86°,-85°

Maximum horizontal rotation: ±180°

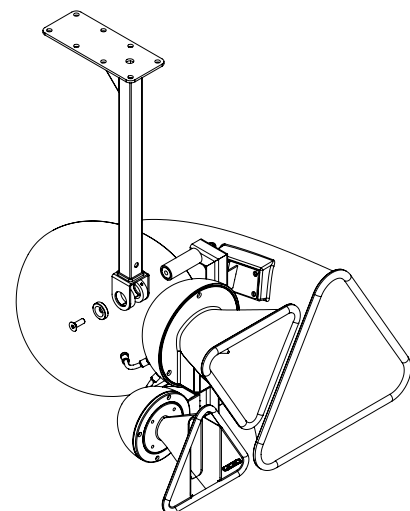

Figure 5.19: Tri Motion ceiling mounting

5.6 Truss Mounting

Parts required:

TU - Truss Bracket	White - IT1082
	Black - IT1081

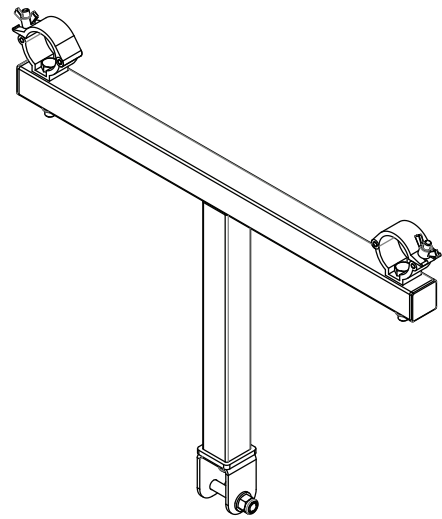

Figure 5.20: TU - Truss Bracket

Step 1:

Remove the wing-nuts from the couplers and position the bracket in the desired location on the truss.

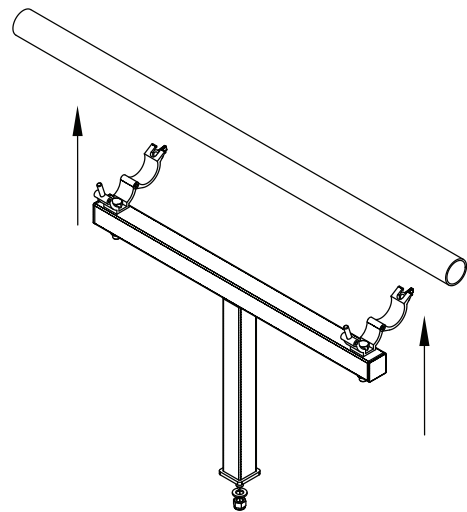

Figure 5.21: Truss bracket positioning

Step 2:

Tighten the wing-nuts on the couplers so that the bracket is securely fastened. Remove the M12 Nyloc nut using a 19 mm ratchet spanner.

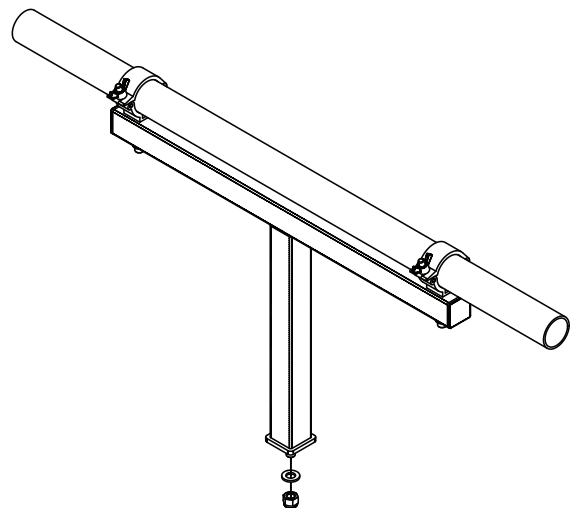

Figure 5.22: Truss bracket fixing

5.6 Truss Mounting

Step 3:

Remove the 'U' bracket assembly as described in section 5.3 and attach it to the truss bracket as shown in figure 5.23

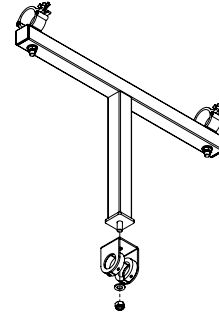

Figure 5.23: Attach 'U' bracket to truss bracket



Step 4:

Lift the Tri Motion with two people (with one hand on the edge of the horn flare and the other supporting the weight of the drivers at the rear) and position the mounting hole over the stand bolt. For safe handling locations see section 2. Once in position adjust the position then tighten the M5 bolts as shown in figure 5:10.

Maximum vertical rotation: $+86^{\circ}, -85^{\circ}$

Maximum horizontal rotation: $\pm 180^{\circ}$

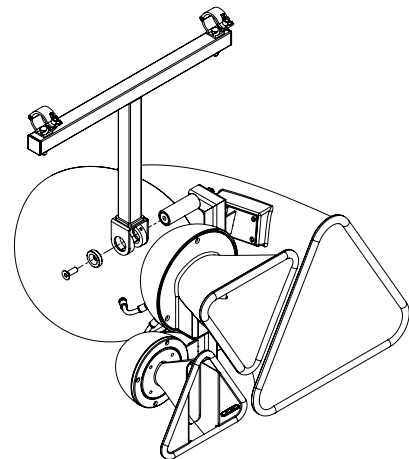

Figure 5.24: Tri Motion truss mounting

5.7 Ceiling Pole Mounting

Parts required:

TU - Ceiling Bracket (500mm)	White - IT2817
	Black - IT2816
TU - Ceiling Bracket (1000mm)	White - IT3486
	Black - IT3485
TU - Ceiling Bracket (1500mm)	White - IT3149
	Black - IT2462

Note: Pole can be cut to length and re-drilled on site should interim lengths be required.

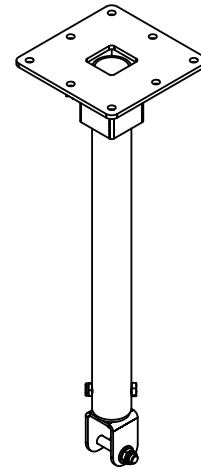

Figure 5.25: TU - Ceiling Bracket

Step 1:

Remove the 'U' bracket assembly as described in section 5.3 and attach it to the ceiling bracket as shown in figure 5.26

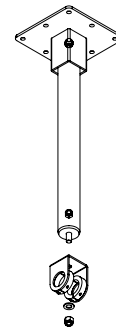

Figure 5.26: Attach 'U' bracket to ceiling bracket



Step 2:

Lift the Tri Motion with two people (with one hand on the edge of the horn flare and the other supporting the weight of the drivers at the rear) and position the mounting hole over the stand bolt. For safe handling locations see section 2. Once in position adjust the position then tighten the M5 bolts as shown in figure 5:10.

Maximum vertical rotation: +86°,-85°
 Maximum horizontal rotation: ±180°

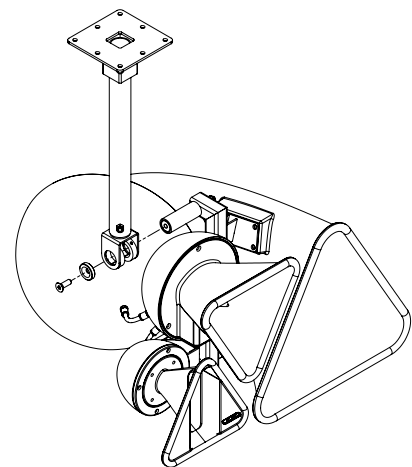

Figure 5.27: Attaching the Tri Motion

5.8 Pole Mounting

Parts required:

TU - Pole Bracket	White - IT3514
	Black - IT3513

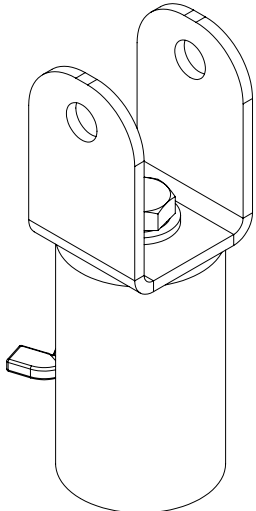

Figure 5.28: TU - pole bracket

Step 1:
Remove the M12 bolt from the pole mount bracket.

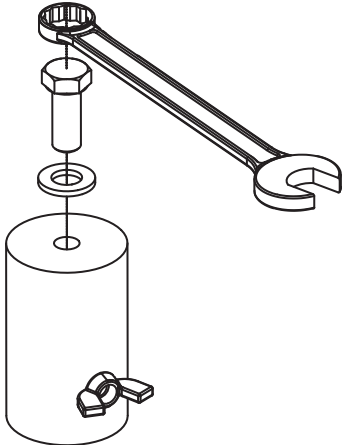

Figure 5.29: Pole mount bracket removal

Step 2:
Mount the pole mount bracket to the U bracket.

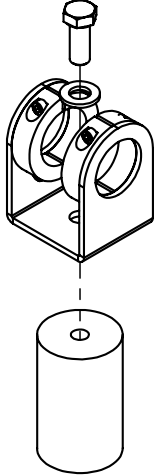

Figure 5.30: Mounting to the U bracket

5.8 Pole Mounting

Step 3:

Attach the U bracket to the Tri Motion as shown in section 5.2. Lift the Tri Motion loudspeaker into position taking care to follow the safe handling positions detailed in section 2.

Adjust the loudspeaker into the desired position and then tighten the wing nut on the pole mount bracket.

Maximum vertical rotation: $+86^{\circ}, -46^{\circ}$

Maximum horizontal rotation: $\pm 180^{\circ}$

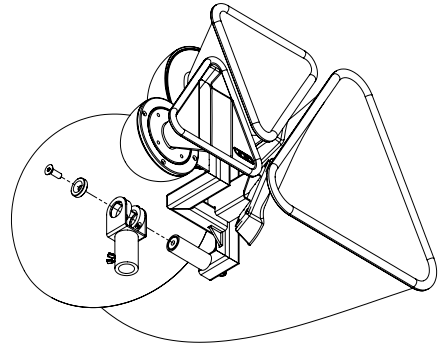

Figure 5.31: Attaching the Tri Motion

6 Service

Void Tri Motion loudspeakers should only be serviced by a fully trained technician.



No user serviceable parts inside. Refer servicing to your dealer.

6.1 Return authorisation

Before returning your faulty product for repair, please remember to get an R.A.N. (Return Authorisation Number) from the Void dealer who supplied the system to you. Your dealer will handle the necessary paperwork and repair. Failure to go through this return authorisation procedure could delay the repair of your product.

Note that your dealer will need to see a copy of your sales receipt as proof of purchase so please have this to hand when applying for return authorisation.

6.2 Shipping and packing considerations

- When sending a Void Tri Motion loudspeaker to an authorised service centre, please write a detailed description of the fault and list any other equipment used in conjunction with the faulty product
- Accessories will not be required. Do not send the instruction manual, cables or any other hardware unless your dealer asks you to
- Pack your unit in the original factory packaging if possible. Include a note of the fault description with the product. Do not send it separately
- Ensure safe transportation of your unit to the authorised service centre.

7 Appendix

The loudspeaker shall be an active three-way bi-amped system consisting of one high power 15" (380 mm) isometric triangular horn loaded low frequency (LF) transducer with a two way mid-high frequency section consisting of an 8" (200 mm) isometric triangular horn loaded mid-high frequency (MHF) transducer and one 1.5" (38.1 mm) diameter exit high frequency (HF) compression driver mounted on a waveguide. Both the LF and MHF transducers shall be enclosed in separate and independent moulded fibreglass composite cabinet with a smooth cellulose finish of any RAL colour.

The LF and MHF transducers shall be constructed on a cast aluminium frame, with a treated paper cone, 63.5 mm (4") for the LF and 50.8 mm (2") for the MHF voice coil, wound with copper wires on a high quality voice coil former, for high power handling and long term-reliability. The HF transducer shall project its sound through a high precision wave-guide with a 200 mm (8") baffle to achieve pattern control and low distortion.

Performance specifications for a typical production unit shall be as follows: the usable on-axis bandwidth shall be 120 Hz to 20 kHz (± 3 dB) and shall average 60° directivity pattern on the vertical axis and 90° on the horizontal one (-6 dB down from on-axis level) from 1 kHz to 12 kHz. Maximum SPL shall be 141 dB peak measured at 1 m using IEC268-5 pink noise. Crossover points shall be at 500 Hz and 1.4 kHz using 3rd order filters (18 dB per octave). The system shall be powered by its own dedicated power amplification module with DSP management. The wiring connection shall be via two Neutrik speakON™ NL4 (one for input and one for loop-out to another speaker), to allow for pre-wiring of the connector before installation.

The enclosures shall be bolted onto a powder coated steel frame using no less than four M8 bolts per horn. This frame aligns the horns in the correct acoustic space to achieve constant directivity across the loudspeaker system's entire dispersion. The frame will incorporate mounting holes for a U bracket fixture for attaching to ceiling, wall and ground stack mounting brackets. The external dimensions of the enclosures and frame shall be (W) 810 mm x (H) 515 mm x (D) 720 mm (31.9" x 20.3" x 28.3"). Weight shall be 47.1 kg (103.8 lbs).

The loudspeaker shall be the Void Acoustics Tri Motion.

NORTH AMERICA

Void Acoustics North America

Call: +1 503 854 7134

Email: sales.usa@voidacoustics.com

HEAD OFFICE

Void Acoustics Research Ltd,
Unit 15, Dawkins Road Industrial Estate,
Poole, Dorset,
BH15 4JY
United Kingdom

Call: +44(0) 1202 666006

Email: info@voidacoustics.com



Hear. Feel. Connect.

voidacoustics.com