

NEXT
proaudio
||| www.next-proaudio.com

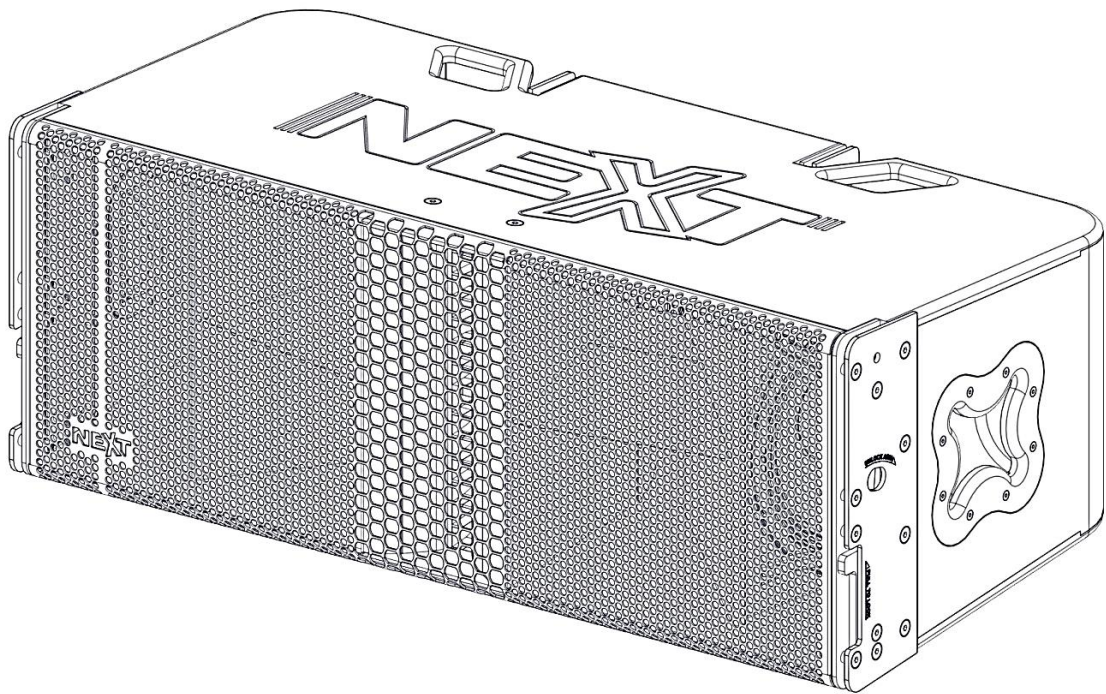

LA212X_{v2}

**3-Way Fully Horn Loaded
Line Array Element**

USER MANUAL

V201610

CONTENTS

INTRODUCTION	- 1 -
SAFETY FIRST	- 1 -
UNPACKING	- 3 -
LA212X _{v2} OVERVIEW	- 3 -
CONNECTIONS AND ELECTRIC DIAGRAM	- 4 -
AMPLIFICATION	- 5 -
CABLE SELECTING	- 6 -
RIGGING SYSTEM	- 7 -
TROUBLESHOOTING	- 9 -
WARRANTY	- 9 -
TECHNICAL SPECIFICATIONS	- 10 -
NOTES	- 11 -
CONTACTS	- 12 -

INTRODUCTION

Thank you for purchasing a NEXT-proaudio LA212Xv2 3-Way Fully Horn Loaded Line Array Element. This manual will provide you with useful and important information about your NEXT LA212Xv2 element. Please devote some time reading this manual, and keep it at hand for future reference. NEXT-proaudio is concerned with your safety and well-being, so please follow all instructions and heed all warnings. Also, a better understanding of some specific features of the LA212Xv2 line array element will help you to operate your system to its full potential. With a continuous evolution of techniques and standards, NEXT-proaudio, reserves the right to change the specifications of its products without early warning. For the most current data, please visit our website: www.next-proaudio.com

SAFETY FIRST

It's important that loudspeaker systems are used in a safe manner. Please take some time to review the following points concerning safe use of the NEXT-proaudio LA212Xv2 Line Array element.

DANGER – HEARING DAMAGE

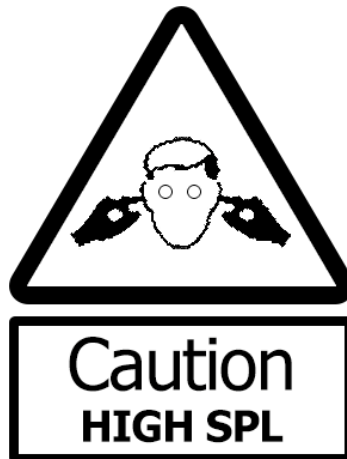

NEXT-proaudio LA Series systems are capable of producing extremely high sound pressure levels and should be used with care. Hearing loss is cumulative and can result from levels above 90dB if people are exposed for a long period. Never stand close to loudspeakers driven at high levels.

GROUND STACKING

- Always ensure that the floor or structure where the stack will be placed is even and can withstand the weight of the complete stack.
- Do not stack speakers too high, especially outdoors where winds could topple the stack.
- Place cables in a way that they do not present a trip hazard.
- Do not place any objects on top of the stack, they can fall accidentally and cause injuries.
- Do not attempt to move the enclosures while connected.
- Try not to operate the LA212X_{v2} under heavy rain or moisture, it is weather-resistant but not completely “weather-proof”.
- Do not expose the systems to extreme heat or cold conditions to prevent component damage.

RIGGING AND SUSPENSION SAFETY CONSIDERATIONS

- Before rigging or suspending NEXT-proaudio LA212X_{v2} systems, inspect all components and all hardware for any signs of damage or missing parts. If you find any damaged, corroded or deformed parts, do not use them, replace them immediately.
- Do not use hardware that isn't load rated or that its' rating is not enough to handle the system's weight with a good safety factor. Don't forget that the hardware won't just hold the systems weight. It has to be sturdy enough to handle dynamic forces like winds without any part deformation.
- NEXT-proaudio advises customers to contact a licensed, professional engineer regarding equipment installation.
- NEXT-proaudio LA212X_{v2} system installation should only be carried out by qualified personnel.
- Always use adequate protective clothing and equipment to prevent possible injuries.
- Only install the systems on solid, levelled ground and isolate the surrounding area during installation and operation, to prevent general public presence near the systems.
- Be sure you understand all local and national regulations regarding equipment installation.
- Negligence or failure to comply with these instructions may result on injury or death.

UNPACKING

Each NEXT-proaudio LA212X_{v2} Line Array element was built in Europe (Portugal) by NEXT-proaudio, to the highest standard and thoroughly inspected before it left the factory. When unpacking the NEXT-proaudio LA212X_{v2}, examine it carefully for any signs of possible transit damage and inform your dealer immediately if any such damage is found.

It is suggested that you retain the original packaging so that the system can be repacked in the future if necessary. Please note that NEXT-proaudio and its authorized distributors cannot accept any responsibility for damage to any returned product through the use of non-approved packaging.

LA212X_{v2} OVERVIEW

Following the huge success of the LA12 line array system and after an extended period of research and development, NEXT-proaudio presents a state-of-the-art line array element, the LA212X_{v2}.

The LA212X_{v2} is a 3-way fully horn loaded, axially symmetric, line array element, capable of producing crystal clear, detailed and extremely powerful audio performance over distance, with an exceptional 90° horizontal constant dispersion control. Being completely symmetric this line array is capable of generating virtually identical acoustic sound patterns on the right and left which allows for an easy, accurate and symmetric alignment. It incorporates a number of technologies to produce a coherent vertical wave front, extreme sound pressure levels with exceptional accuracy and specially consistent horizontal coverage over a wide frequency range, kept down to 280 Hz. Maintaining directivity control over this wide bandwidth raises the ratio of direct-to-reflected energy, thereby increasing system intelligibility.

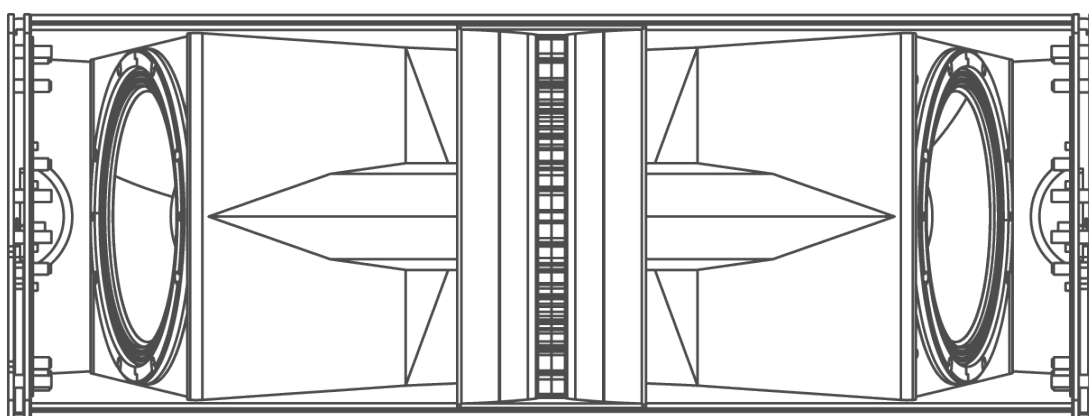

CONNECTIONS AND ELECTRIC DIAGRAM

The LA212X_{v2} is connected through Neutrik® SpeakON® NL8 plugs (not supplied). A wiring description is printed on the connections panels located on the back of the cabinet.

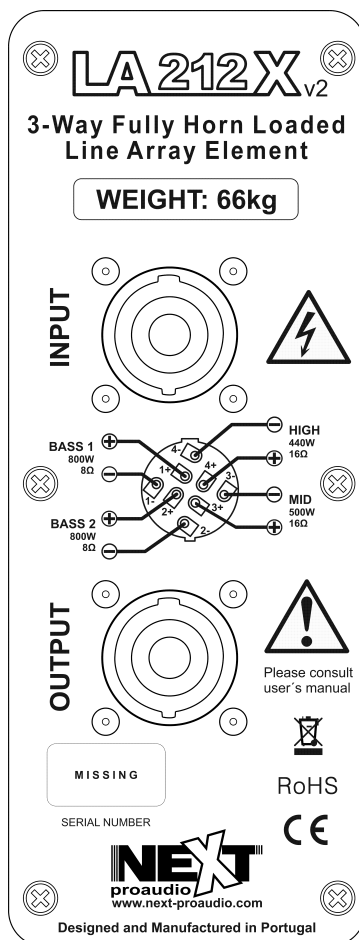

The 8 pins of the two Neutrik® NL8 SpeakON® sockets are wired in parallel within the enclosure. Either connector can be used to connect to the amplifier or another LA212X_{v2} element. Please notice that LA212X_{v2} Line Array elements are four way systems. See the table and the diagram below:

NL8 PIN	Description
1+	Bass_1 +
1-	Bass_1 -
2+	Bass_2 +
2-	Bass_2 -
3+	Mid +
3-	Mid -
4+	High +
4-	High -

ELECTRIC DIAGRAM

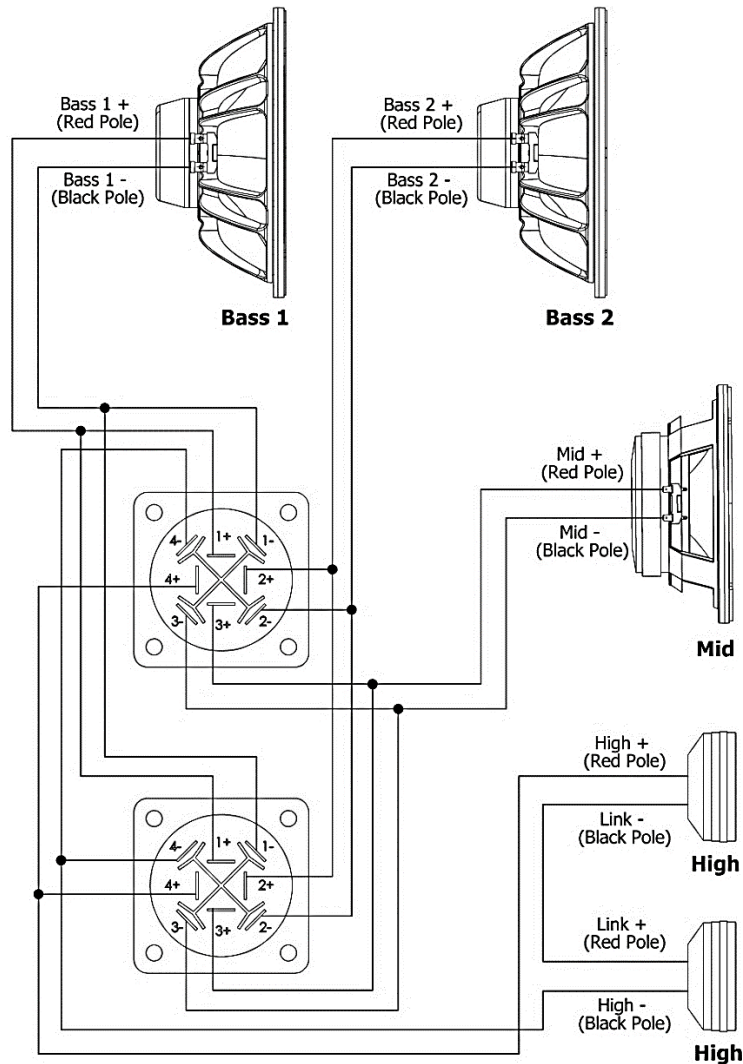

AMPLIFICATION

Normally, LA212Xv2 systems are also supplied with NEXT-proaudio power-rack mounts already configured for optimum performance, according to the configuration chosen by the customer. NEXT-proaudio recommends using only NEXT-proaudio approved amplifiers and signal processing units, and only provides signal processing configuration files for approved signal processing units.



WARNING - Be advised that due to some specific features and technologies employed on the LA212Xv2 element, you will damage the speakers if the wrong crossover configuration is employed, especially the mid-range unit.

The LA212X_{v2} element is a passive three-way system. The high frequency band is reproduced by two 1.4" drivers connected in serial, having a combined nominal impedance of 16Ω. The mid frequency band is reproduced by one 10" driver with a nominal impedance of 16Ω. The low frequency band is reproduced by two 12" drivers with 8Ω nominal impedance separated into two different channels, for power-handling purposes. See the table below for recommended power amplifier power:

2 x LA212X_{v2} Line Array Element (parallel)	
Input	Recommended Amplifier (1 channel)¹
Bass 1	1600W @ 4Ω
Bass 2	1600W @ 4Ω
Mid	1000W @ 8Ω
High	800W @ 8Ω

CABLE SELECTING

Selecting a cable consists of calculating the correct cable section (size) in relation to the load impedance and the required cable length. A small cable section will increase its serial resistance, which will induce power-loss and response variations (damping factor).

The following table indicates, for 3 common sizes, a cable length with a maximum serial resistance equal to 4% of the load impedance (damping factor = 25):

Cable section	Maximum Length related to load impedance	
	8Ω	4Ω
1.5 mm²	12m [40 ft]	6m [20 ft]
2.5 mm²	20m [64 ft]	10m [32 ft]
4 mm²	32m [104 ft]	16m [52 ft]

¹ - Power ratings are indicated according to the specific load conditions described. For more accurate information on NEXT-proaudio amplifiers, visit www.next-proaudio.com

RIGGING SYSTEM

The LA212X_{v2} has a simple and intuitive four-point rigging system. It has two sliding joints on the front and two rear adjustable joints. The rear joints let you define the angle between two elements. It has a controlled vertical dispersion and its angle is adjustable from 0° to 8° relative to the upper element.

The LA212X_{v2} systems use two different rigging frames. The first is an all-around versatile structure, the NEXT NC18212, which allows the rigging of up to 12 LA212X_{v2} elements and ground-stacking of up to 6 LA212X_{v2} elements, either directly on the ground or on top of the LAs418 subwoofer elements. The second rigging frame, NEXT-proaudio NC28212, is a more robust structure designed only for suspended use, which allows the rigging of up to a 20 LA212X_{v2} element system.

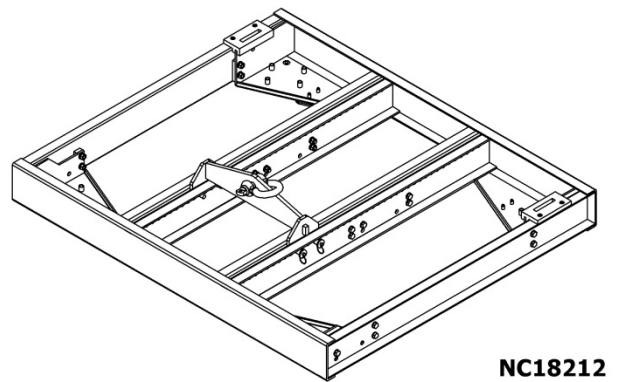
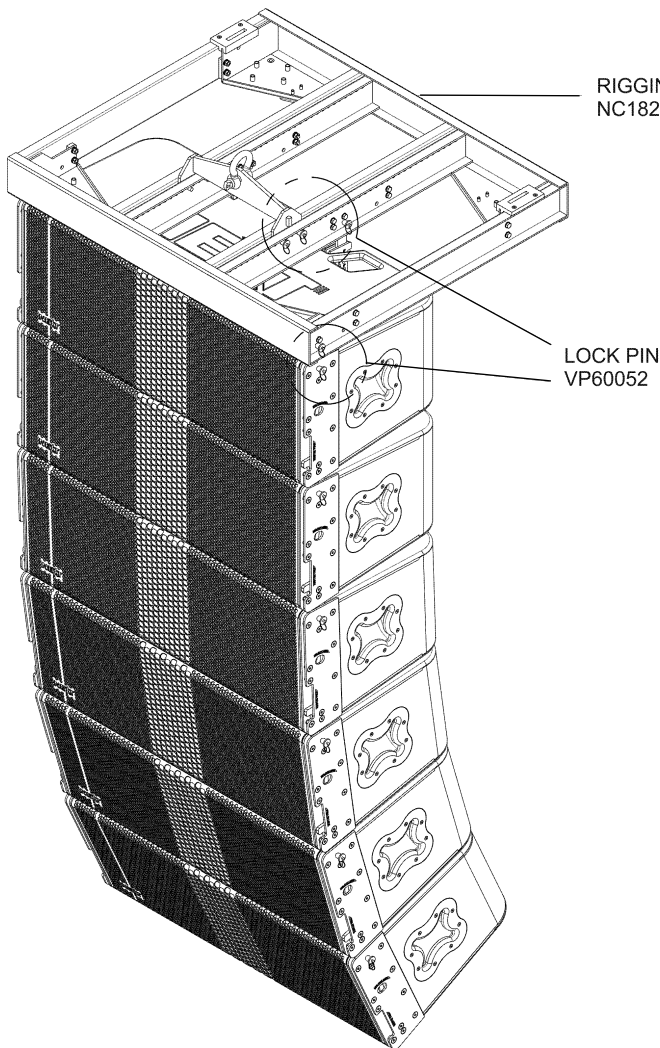

NEXT-proaudio Rigging Frame

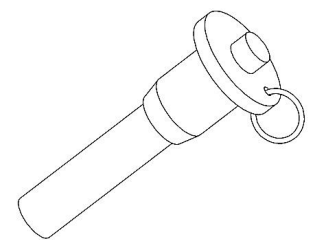

VP60052

NEXT-proaudio Lock Pin



Never use any lock pins but the ones supplied by NEXT-proaudio. These pins are built to withstand the system's weight with a good safety factor and have very specific dimensions.

Now, the LA212Xv2 element is one of the easiest systems to assemble in the market. In its front, the flying system is comprised of a sliding arm with a specially designed locking system. To unlock the arm, just push the latch (1) towards the back of the LA212Xv2 element. If it stands as in the picture below, gravity will work for you and bring it down. To lock it, pull the arm up (2). You can expect some resistance when locking, this is normal. It is a robust locking system designed to be able to withstand force. You can pull the arm faster, so the resistance to locking isn't much noticeable, or hold the latch to facilitate the arm positioning.

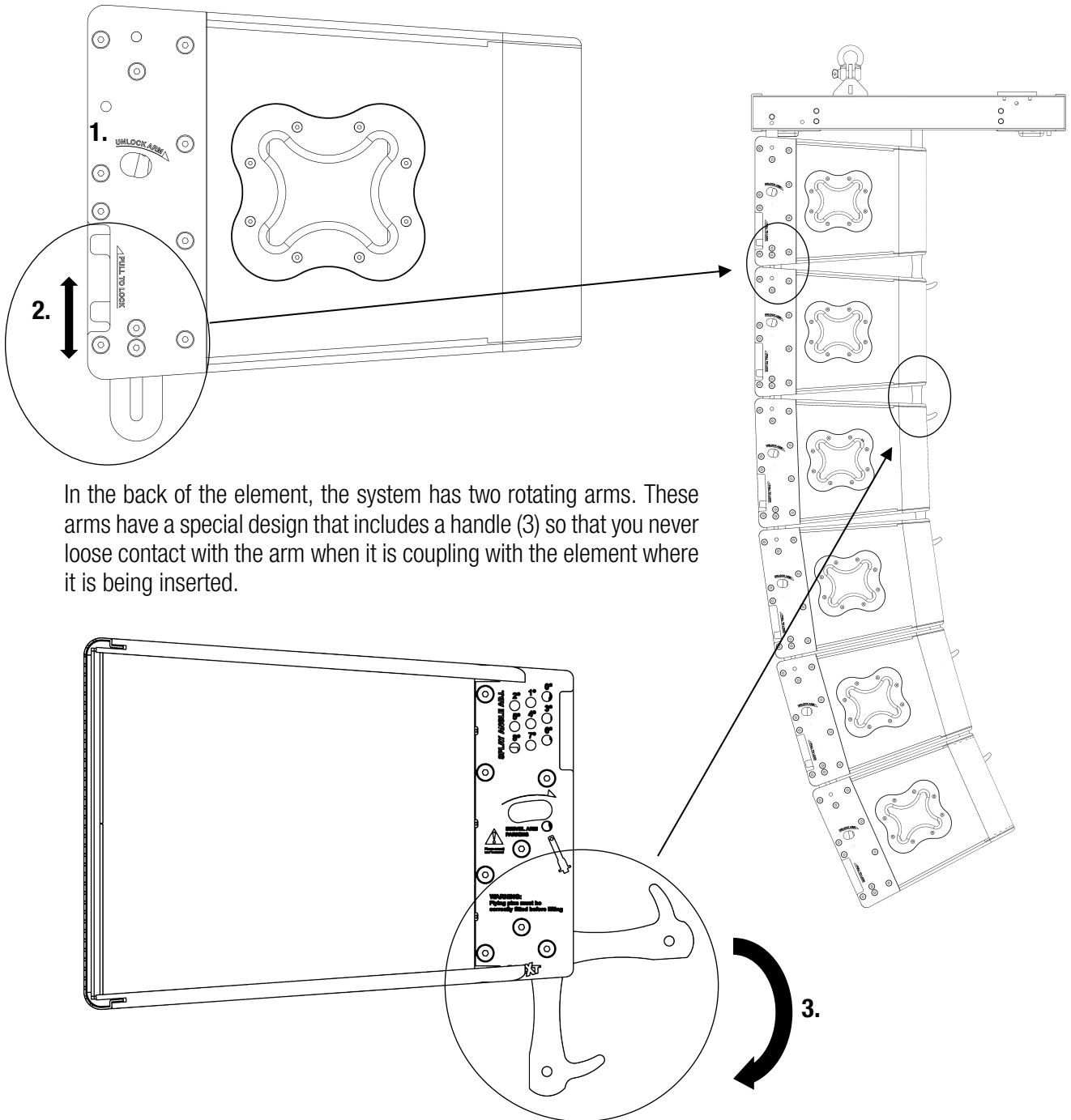

In the back of the element, the system has two rotating arms. These arms have a special design that includes a handle (3) so that you never lose contact with the arm when it is coupling with the element where it is being inserted.

The splay angle between elements is adjusted through the holes in the upper side of the base structure. These holes are marked with the angle they produce.

TROUBLESHOOTING

Simple troubleshooting does not require sophisticated measurement equipment and can be easily undertaken by users. The technique should be to segment the system in order to identify the faulty system component: signal source, controller, amplifier, loudspeaker or cable? Most installations are multi-channel. It is often the case that one channel works and others do not. Trying different combinations of system elements can usually help to isolate and locate the fault.

Some cabinet faults can be quite easily identified and corrected by the user. A simple sweep with a sine wave generator can be very helpful though it **MUST** be made at a fairly low level to prevent damage to the speakers. A sine wave sweep can help find:

- Vibrations due to loose screws.
- Air-leak noises: check that no screws are missing, particularly where the accessories attach to the cabinet.
- Vibrations due to a front grille badly positioned on the quick release fixings.
- Foreign object that has fallen into the cabinet after repair or through the ports.
- Internal connection wires or absorbing material touching the loudspeaker diaphragm: check by removing the bass loudspeaker.
- Loudspeaker not connected or phase reversed following a previous inspection, test or repair.

WARRANTY

NEXT-proaudio's products are warranted, by NEXT-proaudio, against **manufacturing defects** in materials or craftsmanship over a period of 5 years for the passive loudspeakers, and 2 years for all other products counting from the date of original purchase. The original receipt of purchase is mandatory for warranty validation purposes, and the product must have been bought from a NEXT-proaudio authorized dealer.

The warranty can be transferred to a subsequent owner during the warranty period; however, this cannot extend the warranty period beyond the original warranty period of five years from the original date of purchase stated on the NEXT-proaudio's invoice.

During the warranty period NEXT-proaudio will, at its own discretion, either repair or replace a product which prove to be defective provided that the product is returned in its original packaging, shipping prepaid, to an authorized NEXT-proaudio service agent or distributor.

NEXT-proaudio cannot be held responsible for defects caused by unauthorized modifications, improper use, negligence, exposure to inclement weather conditions, act of God or accident, or any use of this product that is not in accordance with the instructions provided by this manual and/or NEXT-proaudio. NEXT-proaudio is not liable for consequential damages.

This warranty is exclusive and no other warranty is expressed or implied. This warranty does not affect your statutory rights.

TECHNICAL SPECIFICATIONS

NEXT LA212X_{v2} TECHNICAL SPECIFICATIONS	
Speaker Type	Horn Loaded 3-Way Line Array Element
Frequency Response (-6dB)	60Hz to 19.000Hz
Coverage Angle -6dB (HxV)	90° (Down to 280Hz) x 8°
Components	LF: 2 x 12" / 3" Voice Coil Custom B&C Speaker
	MF: 1 x 10" / 2.5" Voice Coil Custom B&C Speaker
	HF: 2 x 1.4" / 3" Voice Coil Custom B&C Compression Driver
Program Power	LF - 1600W
	MF - 500W
	HF - 440W
Nominal Impedance	LF - 2 x 8Ω
	MF - 16Ω
	HF - 16Ω
Sensitivity (1W@1m)	LF - 106dB (Full-Space)
	MF - 112dB (Full-Space)
	HF - 114.5dB (Full-Space)
Calculated Max. SPL (Cont/Peak)	LF - 138dB / 141dB (Full-Space)
	MF - 139dB / 142dB (Full-Space)
	HF - 138dB / 141dB (Full-Space)
Recommended Crossover Frequencies (ACTIVE)	LF to MF - 350Hz - 24dB/oct Linkwitz-Riley
	MF to HF - 1050Hz - 48dB/oct Linkwitz-Riley
Recommended HPF (with subwoofers)	75Hz - 24dB/oct Linkwitz-Riley
Fittings	Adjustable (0° to 8°) Rigging System
Construction	15mm Multi-laminate Birch Plywood, Screwed and Glued
Finish	Black Textured Scratch Resistant Paint
Grille	Black-Powder Coated Perforated Grille
Dimensions (W x H x D)	1020 x 379.5 x 500.5 mm
Net Weight	66 kg
Shipping Weight	69.1 kg

Dimensions

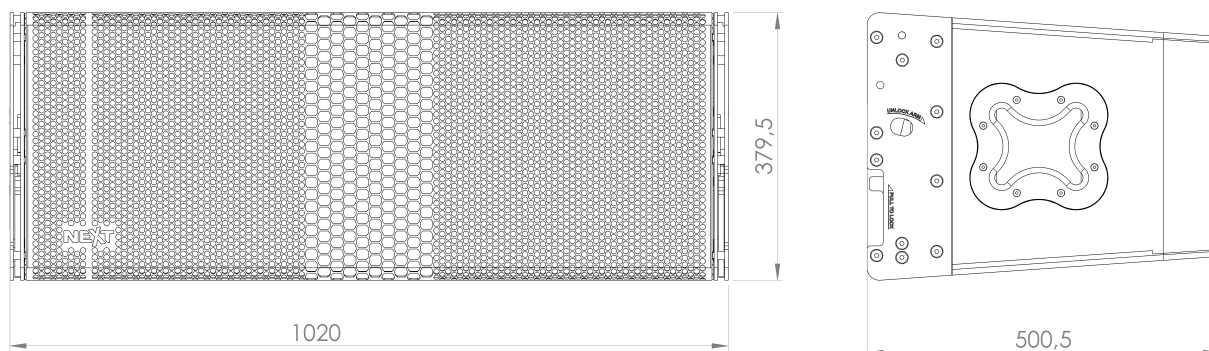

NOTES

A large rounded rectangle containing 25 horizontal lines for taking notes. The lines are evenly spaced and extend across most of the width of the rectangle.

CONTACTS

In case of any doubts or need of information just:

Write us:

NEXT-PROAUDIO
Rua da Venda Nova, 295
4435-469 Rio Tinto
Portugal

Contact us:

Tel. +351 22 489 00 75
Fax. +351 22 480 50 97

Send an e-mail:

info@next-proaudio.com

Search our website:

www.next-proaudio.com

Follow us on:

Facebook: facebook.com/nextproaudio
Instagram: instagram.com/nextproaudio
LinkedIn: linkedin.com/company/next-proaudio
Twitter: twitter.com/next_proaudio
Youtube: youtube.com/user/NEXTmanufacturer