

UNION AUDIO

elara.6



PRODUCT USER GUIDE

Elara.6 User Guide Issue 1

Copyright © 2024 Union Audio Limited. All rights reserved

To the best of our endeavors, we believe the information contained in this user guide to be true and accurate but we do not assume responsibility for inaccuracies or omissions, and reserve the right to make any changes deemed necessary.

UK This product has been designed to comply with the applicable standards, regulations,
and directives for the countries where the product is marketed.

CA **NOTE:** Changes or modifications to this mixer, or its associated power supply, could
negatively impact compliance and the user's authority to operate it.

Designed and manufactured in the United Kingdom by:

Union Audio Limited

Unit 4 Redruth Enterprise Park

Redruth

Cornwall

TR16 5EX

UK

<http://www.unionaudio.co.uk>

WARRANTY

Union Audio warrants the product and accessories contained in the original packaging against defects in materials and workmanship when used in accordance with this user manual for a period of TWO (2) YEARS from the date of original purchase by the end-user purchaser ("**Warranty Period**").

Repair or replacement under the terms of the warranty does not provide right to extension or renewal of the warranty period. Repair or direct replacement of the product under the terms of this warranty may be fulfilled with functionally equivalent service exchange units.

This warranty is not transferable. This warranty will be the purchaser's sole and exclusive remedy and neither **Union Audio** nor any approved service centres shall be liable for any incidental or consequential damages or breach of any express or implied warranty of this product.

Conditions of Warranty

The equipment has not been subject to misuse either intended or accidental, neglect, or alteration other than approved by **Union Audio**. The warranty does not cover potentiometer wear and tear, or cosmetic damage through normal wear. Any necessary adjustment, alteration or repair has only been carried out by **Union Audio** or distributor or appointed service agent.

The defective unit is to be returned to the place of purchase, an authorised **Union Audio** distributor or agent with proof of purchase. Please discuss this with the distributor or the agent before shipping. Units returned should be packed in the original carton to avoid transit damage.

Check with your **Union Audio** distributor or agent for any additional warranty information which may apply. If further assistance is required please contact support@unionaudio.co.uk

Any changes or modifications to the equipment not approved by **Union Audio** could void the compliance of the product and therefore the users authority to operate it.



Safety Instructions

Please read and retain these instructions

- **Only** use the product for the purposes it is intended and heed all warnings.
- **WARNING** - To prevent the risk of fire or electric shock do not use this mixer near water, or in locations where it is likely to be exposed to rain or moisture.
- **Always** ensure that liquids cannot get spilt over the mixer, and keep all objects filled with liquids, such as vases, drinks glasses, etc. well away from the apparatus.
- **Ensure** adequate ventilation and ensure all ventilation openings are not blocked or restricted.
- **Do not** operate the mixer where it is exposed to direct sunlight for long periods, as high chassis temperatures could create internal overheating of the electronics, resulting in premature failure.
- **Do not** connect the output of amplifiers to this apparatus. Always use the correct, high quality cables to connect the mixer to audio sources and power amplifier inputs.
- **Do not** install the mixer near any heat sources such as radiators, stoves, amplifiers or other apparatus that generates heat.
- **Do not** place sharp or heavy objects onto the mixer as these could damage the controls or cosmetics. Avoid rough handling and protect the unit from vibration. Retain the original packing in order to protect the unit during shipping or transit.
- **Refer** all servicing to qualified personnel. Servicing is required if liquids are split onto the mixer or objects have fallen into the apparatus, the unit has been dropped, or does not function normally.



Safety Instructions

- Do not remove any covers.
- Install only in accordance with the manufacturer's instructions.
- **The power supply must have a good safety ground connection.**
- **Do not tamper with or remove the safety ground in the power cord.**
- Always use a power cord appropriate to your local mains supply.
- Protect the power cord from being walked on, pinched, or stretched.
- Unplug the mixer during electrical storms.
- Do not leave the apparatus unattended for long periods when powered on.

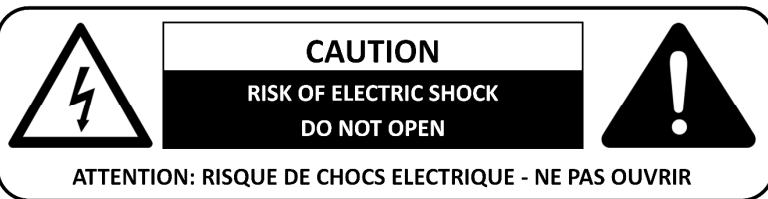

To prevent the risk of electrical shock do not open the mixer or remove any covers. no user serviceable parts inside. Refer servicing to qualified service personnel only.

These symbols are internationally accepted symbols to warn of potential hazards with electrical products.



This symbol indicates that a dangerous voltage constituting a risk of electric shock is present within this unit.



This symbol indicates that there are important operating and maintenance instructions in the literature accompanying this product.

About Elara.6

Overview

The elara.6 is a premium, no-compromise, audio mix tool designed for both club installation and the professional DJ/Live-Producer.

The elara.6 features four, dual input channels, each with a 4-band EQ, carefully tuned for maximum musicality, and two Auxiliary sends. In addition, each channel has a dual Cue for easy artist handover, or Back-to-Back sets, and a beautifully weighted fader with an ultra-linear curve.

On either side of the four main channels are the two Analogue Processing (AP) strips, taking creativity to new levels. Each AP section features a raft of creative tools - Filter (switchable High-Pass or Low-Pass) with Resonance and Frequency controls.

The Drive control, with active side-chain, can be used to add subtle character to the mix, or maxed for the darkest, deepest distortion, while retaining high frequency clarity and stereo imagery.

Unique to the elara.6 is the audio Width control. This adjusts the stereo content of each track from Mono to Reverse Stereo, to Extra-Wide. Used in conjunction with the Filters and Drive, the Width control allows you to create euphoric transitions or moody breakdowns, at the press of a button.

For further audio processing, the output from each AP can be routed to the Auxiliary 1 Send, either pre or post the AP ON switch, and sent to an external FX processor.

The two Mic/Stereo Returns feature a 4-band EQ with semi-parametric swept mid, plus a further 2 Auxiliary Sends and dual Cue system. The Returns can also be routed to the AP system and Crossfader and used as normal mix channels.

Finally, the elara.6 can be easily configured as either a Linear Fader or Rotary Fader by swapping over the optional fader plates - *refer to your local service agent.*

Additional Highlights

- Premium construction with fully machined alloy panel.
- Internal universal voltage power supply.
- Booth Output with balanced XLR
- Innofader crossfader with adjustable curve
- Pre/Post EQ monitoring, with Split and Cue/Mix
- Dual Cue system for Back to Back DJ sets and Handovers.

INDEX

Warranty	3
Safety Information	4
About the elara.6	6
Front Panel drawing	8
Stereo Returns	9
Analogue Processing Strips	10
Main Channels	11
Master Section	12
Rear Panel Drawing	13
Rear Panel Connections - Outputs.....	14
Rear Panel Connections - Inputs.....	15
Block Diagram	16
Specification	17
Mixer Dimensions	18

FRONT PANEL OVERLAY

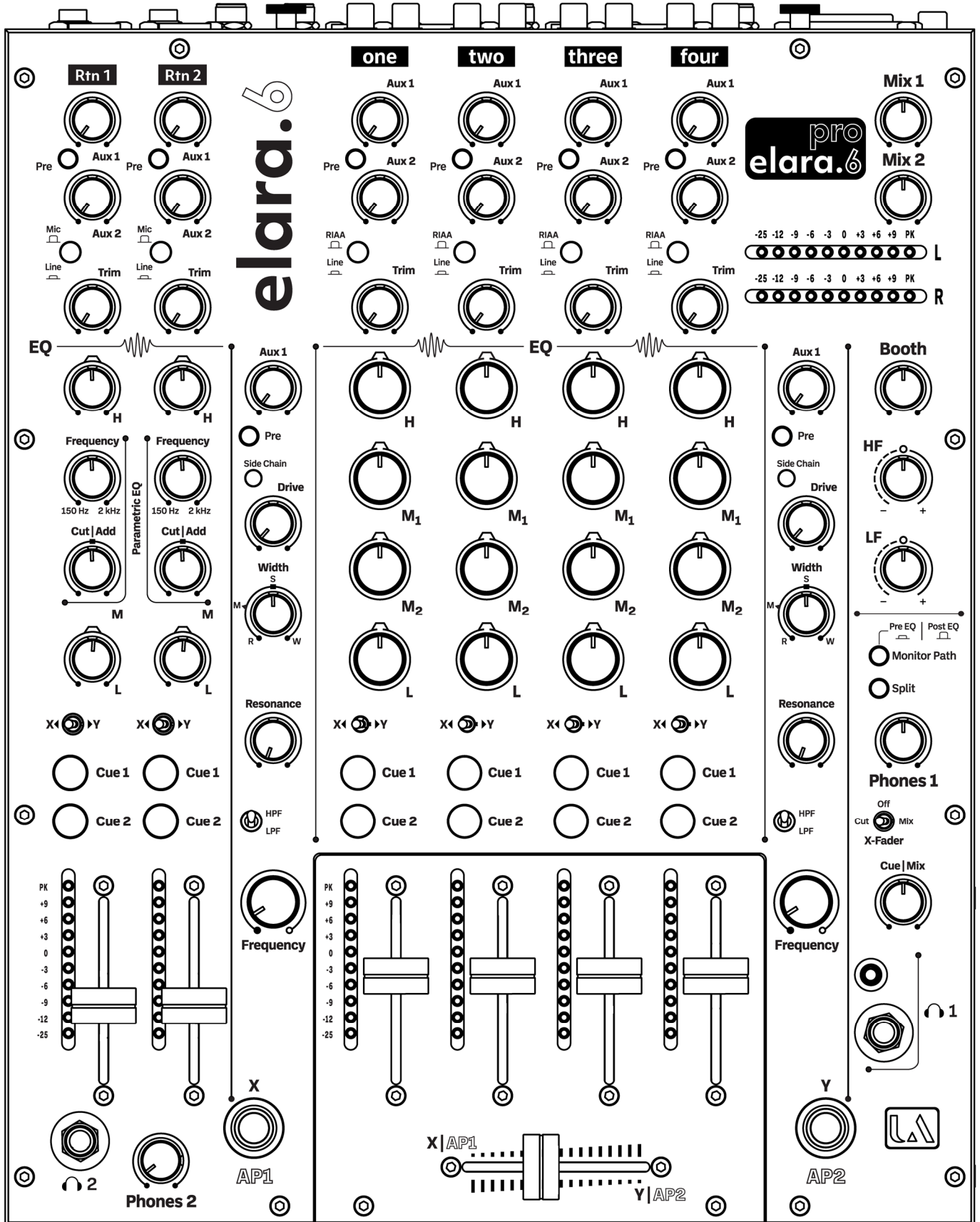

STEREO RETURNS

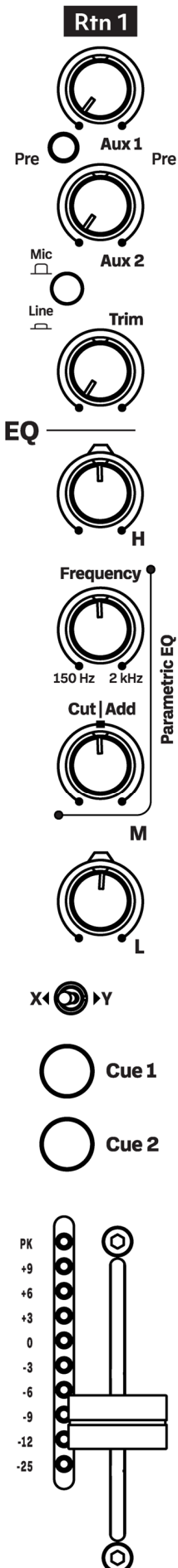

Description

The elara.6 features two fully-featured Stereo Return/Microphone channels located to the left of the mixer front panel. They are used to add additional audio sources to the main mix, as return channels for external effects, or as microphone inputs. Both Stereo Returns can be routed to the Analogue Processors (See page 10) and the crossfader for maximum versatility.

Aux 1-2 – The Auxiliary Send controls the signal level sent to the Aux Outputs, primarily for use with external effects or audio processors, or for stage monitoring.

Pre – Aux 1 can be configured as either pre-fader (down) or post-fader (up), determining where in the signal path the send is sourced from, and how it interacts with the channel's fader level. Pre-fader sends are useful when you need to send a constant signal for monitoring or external processing, while post-fader sends are beneficial for adding effects relative to the channel's level in the main mix, delays reverbs, etc. Aux 2 is permanently configured as a Post Fader send.

Trim – Controls the level of the input signal from fully OFF to a maximum gain of +10dBu. Use in conjunction with the Return VU Meter to set the optimum signal level, with the average lighting the Blue 0VU LED and the peaks just lighting the White +3VU LED.

MIC/Line – Selects the input source for each channel. The Microphone Input is designed to operate with standard non-phantom power dynamic microphones. The Line inputs are fully balanced and can accept signal levels from -10dBu to +20dBu.

EQ - The elara.6 Return channels feature a semi-parametric EQ with swept mid-range and fixed HF and LF. Boost/Cut is symmetrical +/- 15dB with a mid frequency sweep range from approximately 150Hz to 2kHz.

See graph below for Return EQ Response.

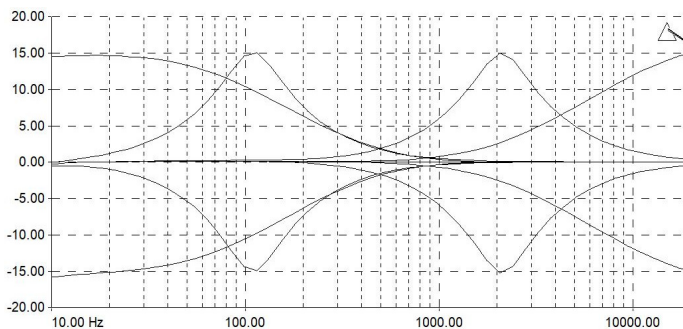

Channel Assignment Switch - Three position toggle switch that routes the Return Channel to either the Main Mix (centre position) or to either Analogue Processor strips (X = Left, Y = Right). This switch will also set which side the crossfader the Return is routed to.

Channel Cues - Cue 1 routes to the main Cue System on the Right side of the main panel, Cue 2 to the secondary Cue system. These switches toggle On/Off with each press and illuminate Red when active.

Channel Meter - Indicates the post EQ/Pre fader signal level. Adjust the trim so the average signal level illuminates the -3/0 LED, with peaks illuminating the +3/+6 LED.

Return Fader - 45mm linear fader to adjust signal level fed to the main mix. Unity level is achieved with the fader fully up, and OFF with the fader fully down.

ANALOGUE PROCESSING STRIPS

Aux 1



Pre

Side Chain



Drive



Width

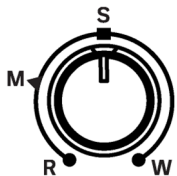

Resonance



HPF
LPF



Frequency

X

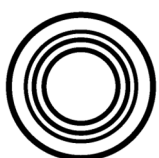

AP1

Description

On either side of the four main channels are the two Analogue Processing (AP) strips. Each AP features a resonant VCF Filter (switchable High-Pass or Low-Pass) with Resonance and Frequency controls, Drive Control with Active Side-chain, and a Stereo Image width control.

The output from each AP can also be routed to the Auxiliary 1 Send, either pre or post the AP ON switch for additional signal processing with an external effects unit.

Aux 1 - Sends the processed output from the AP into the Aux 1 Mix, where it can be further processed with an external FX unit and returned to the Main Mix via the Stereo Returns.

Pre - When the Pre button is pressed it bypasses the AP ON switch, allowing the signal from any Channel (or Return) routed through the Analogue Processor strip, to be sent direct to the Aux 1 mix buss, before the AP is activated in the main mix.

Drive with Side-Chain - The Drive control adjusts the level at which a signal running through the Analogue Processor strip is clipped, thus creating harmonic distortion as an effect. As heavy signal clipping significantly reduces the amplitude, the Drive control features automatic side-chain make-up gain to restore the pre clipped level. The "Side Chain" LED will illuminate brightly when this system is active. NOTE, the side-chain LED always glows dimly as a visual location reference in low light.

The graph below illustrates the effect of maximum Drive on a sine wave.

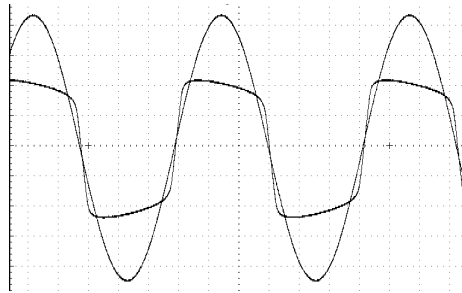

Width - A unique feature, the elara.6 incorporates an **M-S Stereo** Width encoder circuit with easy variable control. This circuit creates a **Mid-Channel** by combining the Left and Right stereo signal, and a **Side-Channel** by subtracting the Left and Right stereo signal. The Width control then varies the ratio of the **Mid** and **Side** signal level, to either reduce the stereo width to Mono, Reverse Stereo, Normal Stereo, or Extra Wide. The effect this control has on the audio is totally dependent on how the stereo image of the track was originally mixed in the studio, but it can introduce some very unique and interesting sounds, especially when used in conjunction with the other tools in the AP strip.

VCF Filter - The VCF Filter can be switched to either a High-Pass Filter (HPF) or Low-Pass Filter (LPF) by flipping the small Toggle switch, creating a swept frequency performance effect, or as pre-set frequency mix tool to instantly cut the low or high frequencies of any channel routed to the Filter.

Resonance - Adjusts the sharpness (Q) of the Filter. Set to minimum the Filter will have a smooth roll off with a low Q. Turning the control clockwise will progressively increase the Q and the gain at the filter cut-off point.

Frequency (LPF) - Progressively attenuates the high frequency content as it is rotated counter clockwise. A flat frequency response up to 20kHz is achieved with the control fully clockwise. With the control set fully counter clockwise all frequencies above 30Hz will be progressively attenuated.

Frequency (HPF) - Progressively attenuates the low frequency content as it is rotated clockwise. A flat frequency response down to 30Hz is achieved with the control fully counter clockwise. With the control set fully clockwise all frequencies below 8kHz will be attenuated.

AP ON - Activates the AP strip. This switch is controlled by a zero-crossing detection system so can be used as a performance effect. The zero crossing system removes audible clicks and switching artifacts when routing channels to the Master Filter or switching the filter ON.

MAIN CHANNEL STRIPS



Description

The elara.6 features four fully featured main channels located in the centre of the mixer front panel. Each channel strip features two Auxiliary Sends, dual Input (Line or RIAA), a powerful 4-Band equaliser, dual Cues and a smooth 45mm linear fader. Unique to the elara.6 is the ability to easily convert the mixer from Fader to Rotary by swapping out the fader tray for the alternate type.

Aux 1-2 – The Auxiliary Sends control the Return signal level sent to the Aux Outputs, primarily for use with external effects or audio processors.

Pre – Aux 1 can be configured as either pre-fader (down) or post-fader (up), determining where in the signal path the send is sourced from, and how it interacts with the channel's fader level. Pre-fader sends are useful when you need to send a constant signal for monitoring or external processing, while post-fader sends are beneficial for adding effects relative to the channel's level in the main mix, delays reverbs, etc. Aux 2 is permanently configured as a Post Fader send.

Trim – Controls the level of the input signal from fully OFF to a maximum gain of +10dBu. Use in conjunction with the Channel VU Meter to set the optimum signal level, with the average lighting the Blue 0VU LED and the peaks just lighting the White +3VU LED.

RIAA/Line – Selects the input source for each channel. The RIAA inputs are for connection to a moving magnet cartridge for vinyl replay. RIAA is selected when the button is out and not illuminated. The line inputs are for connection to Line-Level devices such as CD and Media Players, Soundcards, etc. and the button will illuminate Blue to indicate this selection.

EQ - The elara.6 input channels feature a smooth 4-Band equaliser with asymmetric Boost/Cut of approximately +6dB/-20dB with the dual mid frequency range set at 250Hz and 1.5kHz.

The graph below shows the response of the channel 4-Band EQ.

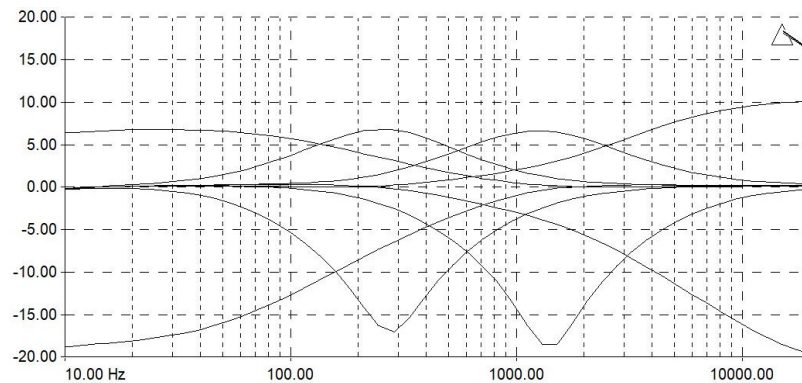

Channel Assignment Switch - Three position toggle switch that routes the Channels to either the Main Mix (centre position) or to either Analogue Processor strips (X = Left, Y = Right). This switch will also set which side the crossfader the Channel is routed to.

Channel Cues - Cue 1 routes to the main Cue System on the Right side of the main panel, Cue 2 to the secondary Cue system. These switches toggle On/Off with each press and illuminate Red when active.

Channel Meter - Indicates the post EQ/Pre fader signal level. Adjust the trim so the average signal level illuminates the -3/0 LED, with peaks illuminating the +3/+6 LED.

Channel Fader - 45mm linear fader (or optional Rotary) to adjust signal level fed to the main mix. Unity level is achieved with the fader fully up, and OFF with the fader fully down.

MASTER SECTION

· **Description**

The Master section includes the two Mix level controls, Main Mix buss metering, the Booth monitor section, and primary Headphone monitor.

Main Meters - Two, ten point peak reading LED meters provide a visual indication of the Mix buss level.

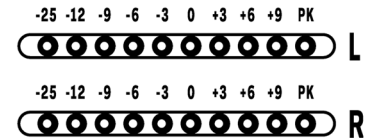

Although the elara.6 has a considerable 28dB of headroom, and is unlikely to suffer from clipping due to high signal levels,

it is recommended to keep the average signal level between -3 and +6. Occasional peaks to +9 is acceptable but operation with the PK LED ON is best avoided due to the possibility of damaging any connected PA systems or clipping soundcards, record devices etc.

When a Channel or Return **Cue 1** Button is activated, the Main Meters will automatically switch-over to give a stereo level reading of the Pre-Fade signal level for that Channel/Return.

When a Channel or Return **Cue 1** is active and the **Split** button is pressed, the Left Meter displays the Cue signal level, and the Right Meter displays the Main Mix buss level.

Mix 1, 2 - These controls set the output level for the two main mix outputs. Mix 1 controls the XLR outputs and Mix 2 the TRS outputs.

BOOTH - These controls adjust the level and frequency response of the Booth outputs. The Booth section also incorporates a 2-Band equaliser allowing the user to adjust the frequency response of the Booth monitors to suit their own preference.

The graph below shows the response of the Booth EQ.

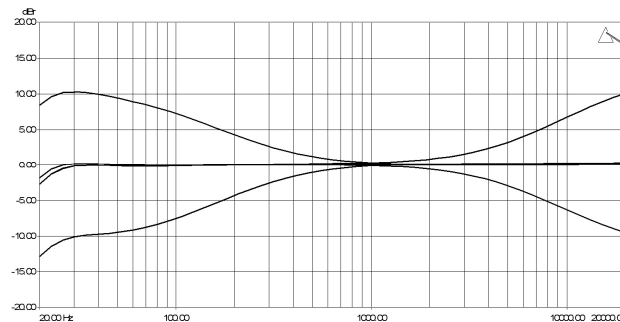

Monitor Path - Pressing this button switches the **Cue 1** system to monitor the Pre-EQ signal path for each Channel and Stereo Return. This means that you will not hear changes made in the EQ, which can be useful if you dramatically alter the frequency response by cutting all LF, but still need to monitor the beats to keep a track in sync.

Split - Switches the Headphone monitor to Split mode. When pressed you will hear the Channel/Return Cue signal in the Left Headphone and the Main Mix in the Right Headphone.

Phones 1 - Adjusts the Phones 1 headphone amplifier output level.

X-Fader - Sets the crossfader curve, from sharp (Cut) to smooth (Mix). The crossfader is deactivated when this switch is in the centre position.

CUE|Mix - Adjusts the balance between monitoring the Channel/Return Cue signal and the Main Mix. When fully anti-clockwise, only the Cue signal is heard. When fully clockwise, only the main Mix is heard. In the centre position Cue and Mix are summed together. When the Split button is pressed, this control will Pan the phones signal between Left (Cue) and Right (Mix).

Phones - 1/4" and 1/8" TRS Jacks for connection of good quality 30 Ohm - 200 Ohm Headphones



Warning! Do not drive headphones at high listening levels for long periods of time as this can cause permanent hearing damage!

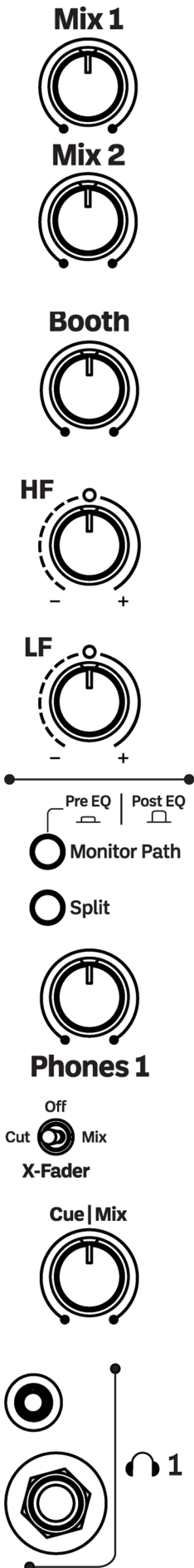

REAR PANEL

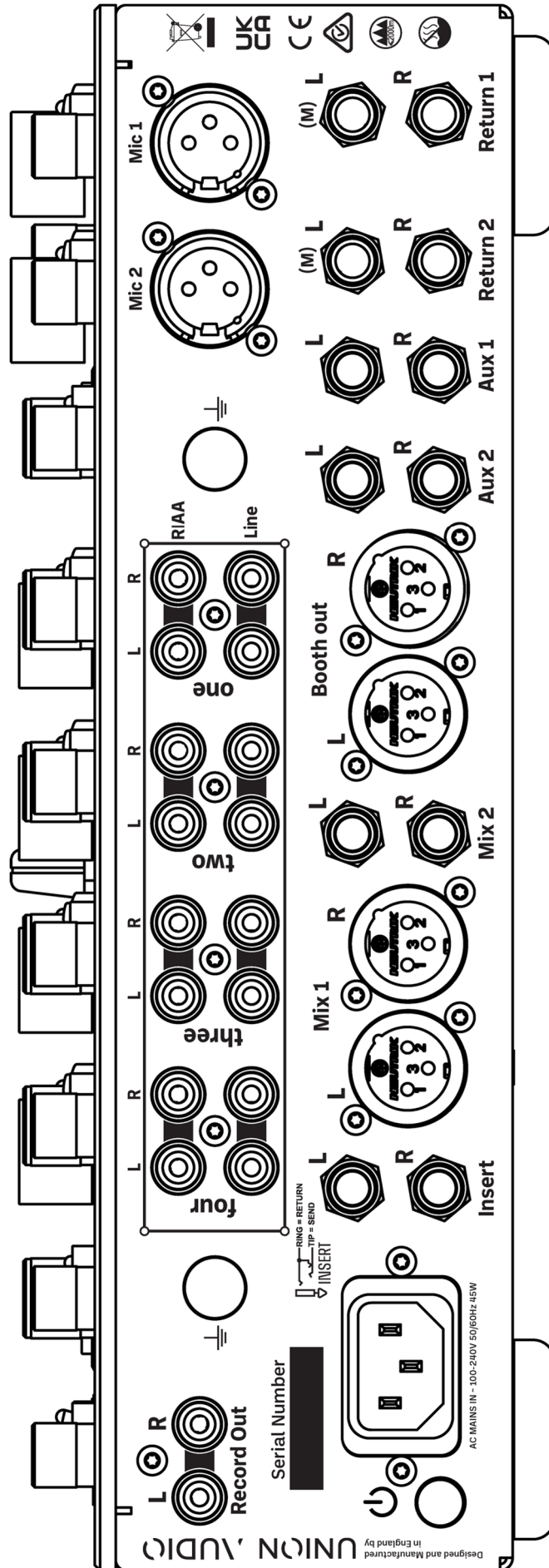

REAR PANEL CONNECTIONS - OUTPUTS

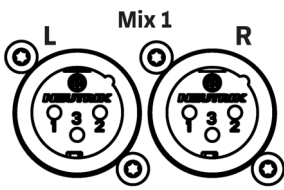

Mix 1 - Main mix outputs for direct connection to the system PA.

Balanced XLR, conventionally configured for:

Pin 1 = Ground

Pin 2 = Positive Phase

Pin 3 = Negative Phase

Nominal output level 0dBu, maximum output level +27dBu.



Mix 2 - Secondary mix outputs for feeding a separate zone or PA.

Impedance balanced 1/4" TRS Jack sockets.



Nominal output level 0dBu, maximum output level +22dBu.

Mix 2

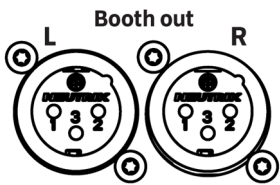

Booth - Provides a stereo feed for local monitoring, independent of the two Mix Outputs.

Balanced XLR, conventionally configured for:

Pin 1 = Ground

Pin 2 = Positive Phase

Pin 3 = Negative Phase

Nominal output level 0dBu, maximum output level +27dBu.



AUX 1, 2 - Outputs to external effects units or local monitor system.

Impedance balanced 1/4" TRS Jack sockets.



Nominal output level -2dBu, maximum output level +22dBu.

Aux



Record Out - Low level RCA output for connection to recording equipment. This output takes its feed directly from the Post Insert Main Mix and is not affected by Mix 1/Mix 2 level controls

Unbalanced RCA.

Nominal output level -8dBu (-10dBV), maximum output level +14dBu.

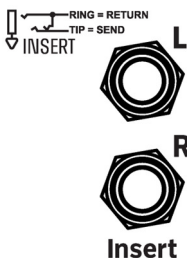

Master Insert - Main Mix Buss Insert connection for external processors, equalizers, effects, etc.

Connector Type = 1/4" TRS Jack

The connections follow the standard convention:

Tip = Send (To external processor)

Ring = Return (From external processor)

Ring = Ground

Nominal output level 0dBu, maximum output level +22dBu.

Requires a TRS Jack splitter lead with appropriate connectors for the device being Inserted (RCA, TS Jack, XLR etc)

REAR PANEL CONNECTIONS - INPUTS

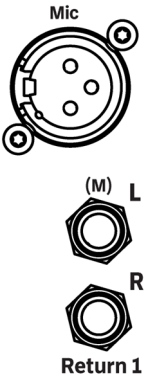

RETURN 1,2

MIC - Balanced XLR connections for use with dynamic Microphones (Sure SM58 etc).

Balanced XLR, conventionally configured for:

Pin 1 = Ground

Pin 2 = Positive Phase

Pin 3 = Negative Phase

Input impedance = 1100 Ohms

Maximum Gain +50dBu.

Line - Balanced 1/4" TRS Jack.

Connection convention:

Tip = Positive Phase

Ring = Negative Phase

Sleeve = Ground.

Signal level range - -10dBu to +20dBu. Impedance 10K Ohm

Connection to the Left Jack only, normalises the input to Mono.

RCA Inputs - Channels 1-4

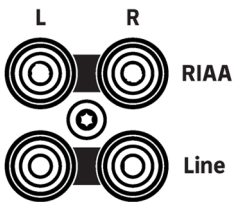

RIAA - For connection to turntables only. These are high gain inputs featuring RIAA (Recording Industry Association of America) equalization for use with moving magnet cartridges. Take care not to plug in line level sources to the RIAA inputs as these will overload the preamp, causing severe distortion, and potentially damage to the sensitive circuitry.

Line - For use with line level output audio sources, media/CD players, soundcards, drum machines, synthesisers, etc.

RIAA Signal level: 0.006V RMS to 0.02V. Impedance 47K Ohm, capacitive loading 100pF.

Line Signal Level: --+20dBu to -10dBu. Impedance 8K Ohm



Ground - Elara.6 features two knurled thumb screws for ground connection from turntables, etc

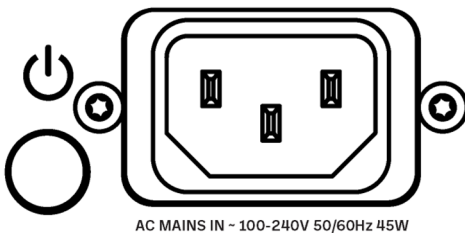

AC Mains Connection - The C14 mains inlet incorporates filtering to remove unwanted high-frequency mains-borne noise.

Always use the correct mains cable for your local territory and ensure it is properly earthed.

The internal power supply automatically compensates for different mains voltages, and can operate between 100VAC and 250VAC, 50Hz or 60Hz.



The Mains Ground connection is important for two reasons:

Safety - To ensure that anyone touching the device is fully protected against potential electrical shock.

Minimise Ground Loops - Best audio performance is obtained when all devices are properly grounded. This helps to avoid ground loops that can create hum and static noise.

BLOCK DIAGRAM

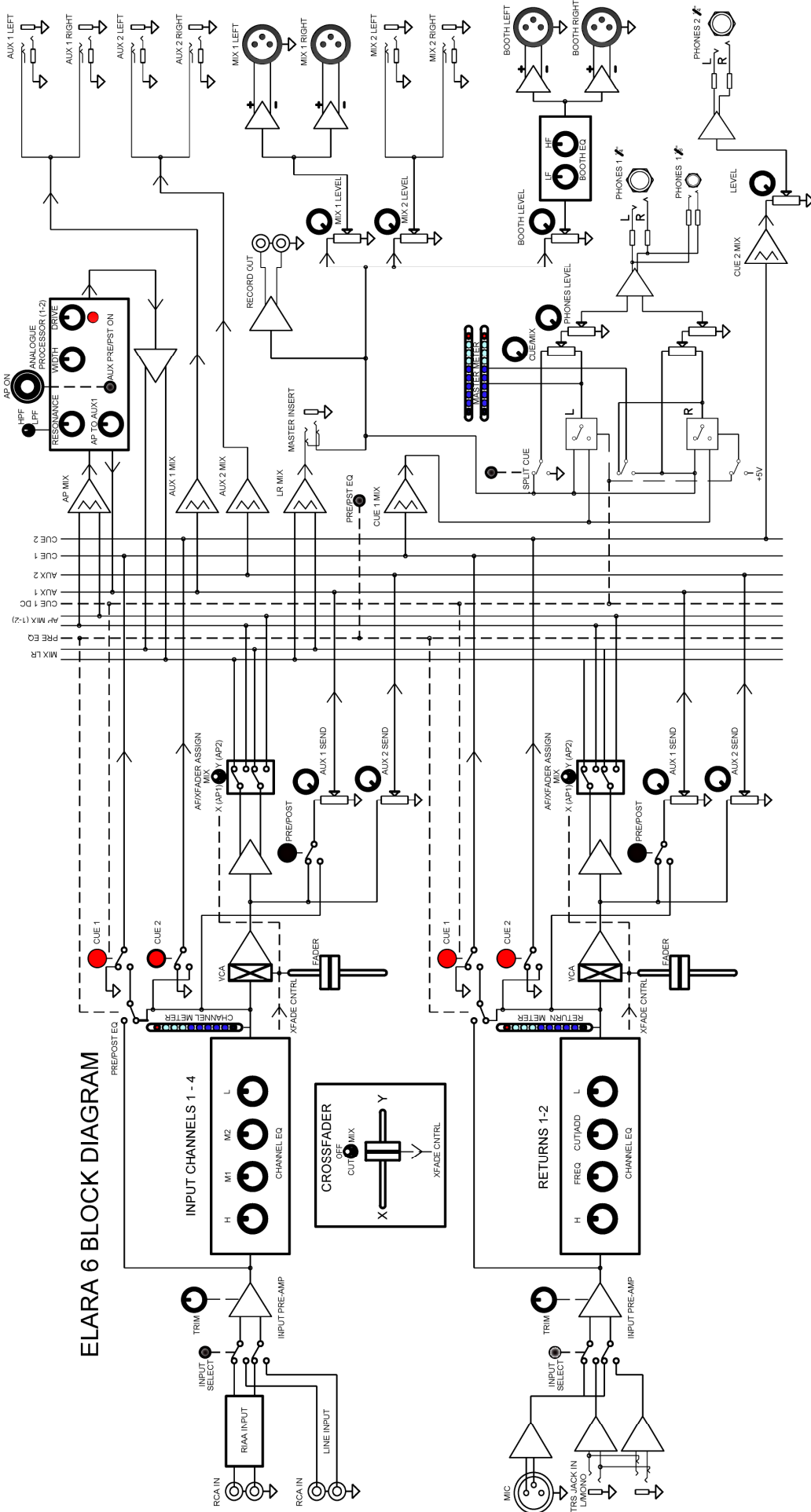

ELARA 6 BLOCK DIAGRAM

SPECIFICATIONS

Maximum output level	+27dBu Balanced, +22dBu Unbalanced
Output Impedance	<1R Balanced, 100R Unbalanced
Noise Line in to Line out Unity	-80dBu Un-weighted, 22Hz to 20kHz
Residual Noise	-92dBu Un-weighted, 22Hz to 20kHz
Dynamic range	> 114dB
Frequency Response	10Hz - 50kHz +/-1dB
Distortion (THD+N)	0.03% Line In to Mix 1 out, 0dBu Unity Gain
Control Attenuation	Better than 80dB
Inter-channel Crosstalk	< -100dB
Left/Right Crosstalk	-80dB 1kHz
Maximum Headphone Output	850mW RMS into 45 Ohms (Cue 1)
Power consumption	40W maximum
Weight	5.30kG (Packed 7.5kG)
Dimensions	L 37cm x W 30cm x H 8cm (Packed L 47cm x W 41cm x H 22cm)

MIXER DIMENSIONS

