

elara.4^{MK2}



PRODUCT USER GUIDE

Elara.4 MK2 User Guide Issue 1

Copyright © 2025 Union Audio Limited. All rights reserved

To the best of our endeavors, we believe the information contained in this user guide to be true and accurate but we do not assume responsibility for inaccuracies or omissions, and reserve the right to make any changes deemed necessary.

This product has been designed to comply with the applicable standards, regulations, and directives for the countries where the product is marketed.

NOTE: Changes or modifications to this mixer, or its associated power supply, could negatively impact compliance and the user's authority to operate it.

Designed and manufactured in the United Kingdom by:

Union Audio Limited

Unit 4 Redruth Enterprise Park

Redruth

Cornwall

TR16 5EZ

UK

<http://www.unionaudio.co.uk>

Limited Two-Year Manufacturer's Warranty

Union Audio warrants the product and accessories contained in the original packaging against defects in materials and workmanship when used in accordance with this user manual for a period of TWO (2) YEARS from the date of original purchase by the end-user purchaser ("**Warranty Period**").

Repair or replacement under the terms of the warranty does not provide right to extension or renewal of the warranty period. Repair or direct replacement of the product under the terms of this warranty may be fulfilled with functionally equivalent service exchange units.

This warranty is not transferable. This warranty will be the purchaser's sole and exclusive remedy and neither **Union Audio** nor any approved service centres shall be liable for any incidental or consequential damages or breach of any express or implied warranty of this product.

Conditions of Warranty

The equipment has not been subject to misuse either intended or accidental, neglect, or alteration other than approved by **Union Audio**. The warranty does not cover potentiometer wear and tear. Any necessary adjustment, alteration or repair has only been carried out by **Union Audio** or distributor or appointed service agent.

The warranty does not cover finger wear to the front panel silkscreen graphics.

The defective unit is to be returned to the place of purchase, an authorised **Union Audio** distributor or agent with proof of purchase. Please discuss this with the distributor or the agent before shipping. Units returned should be packed in the original carton to avoid transit damage.

Check with your **Union Audio** distributor or agent for any additional warranty information which may apply. If further assistance is required please contact support@unionaudio.co.uk

Any changes or modifications to the equipment not approved by **Union Audio** could void the compliance of the product and therefore the users authority to operate it.



Safety Instructions

Please read and retain these instructions

- Only use the product for the purposes it is intended and heed all warnings.
- **WARNING** - To prevent the risk of fire or electric shock do not use this mixer near water, or in locations where it is likely to be exposed to rain or moisture.
- Always ensure that liquids cannot get spilt over the mixer or its power supply, and keep all objects filled with liquids, such as vases, drinks glasses, etc. well away from the apparatus.
- Ensure adequate ventilation and ensure all ventilation openings are not blocked or restricted.
- Do not connect the output of amplifiers to this apparatus. Always use the correct, high quality cables to connect the mixer to audio sources and power amplifier inputs.
- Do not install the mixer or power supply near any heat sources such as radiators, stoves, amplifiers or other apparatus that generates heat.
- Do not place sharp or heavy objects onto the mixer or power supply as these could damage the controls or cosmetics. Avoid rough handling and protect both units from vibration. Retain the original packing in order to protect the unit during shipping or transit.
- Refer all servicing to qualified personnel. Servicing is required if liquids are split onto the mixer or its power supply, objects have fallen into the apparatus, the unit has been dropped, or does not function normally.



Safety Instructions

- Do not remove any covers, either on the mixer or the power supply.
- Install only in accordance with the manufacturer's instructions.
- Always use a power cord appropriate to your local mains supply, and ensure the power supply is correctly specified for the local mains voltage.
- Protect the power cord from being walked on, pinched, or stretched.
- Unplug the power supply and mixer during electrical storms.
- Do not leave the apparatus unattended for long periods when powered on.

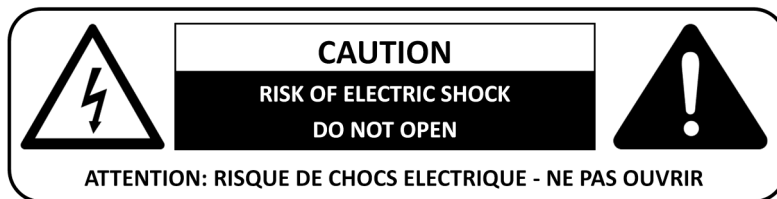

To prevent the risk of electrical shock do not open the mixer or power supply or remove any covers. no user serviceable parts inside. Refer servicing to qualified service personnel only.

These symbols are internationally accepted symbols to warn of potential hazards with electrical products.



This symbol indicates that a dangerous voltage constituting a risk of electric shock is present within this unit.



This symbol indicates that there are important operating and maintenance instructions in the literature accompanying this product.

Index

Contents

Warranty	3
Safety Instructions	4 - 5
Index	6
About the Elara.4 MK2	7
Front and Rear Line Drawing	8
Input Channel Controls	9 - 10
Master Section	11 - 12
Rear Panel Input Connections	13
Master Output Connections	14
Application Diagram	15
Block Diagram	16
Technical Specification	17
Dimensions	18

About Elara.4 MK2

Despite its compact dimensions, elara.4 MK2 has a fully-featured channel strip, with auxiliary send (selectable pre or post fader), channel level trim, a responsive 3 band Equaliser with -20dB attenuation/+6dB of gain, and a high-pass filter with auto-variable Q, whereby Q rises with the cut-off frequency to give the classic filter sound without the danger of excessively boosting low frequencies.

Elara.4 MK2's channels are switchable RIAA/LINE, with the addition of a MIC input on Channel 1. Each channel has a 10 LED meter and a high quality 45mm fader with a weighted feel, for precise mixing. The elara.4 also features an Innofader crossfader with variable contour, and per channel selectable routing via a toggle switch.

A comprehensive Cue system offers per channel pre-fader monitoring, split-cue and add-mix controls. With all Cues off, the headphone monitor defaults to mix, with the stereo 10 LED VU meter showing pre-Master mix buss level. Selecting any Cue automatically switches the Main VU to show the channel pre-fader level, or channel pre-fader and Mix when the split control is active.

Unique to the elara.4 is the master EQ/isolator with variable crossover control, designed to complement the channel EQ and allowing for some highly creative sound sculpturing. The Isolator has a wide "Q" and can be swept from 150Hz to 1kHz (Low-Mid crossover point), with full kill or a safe +6dB of boost.

Elara's other features include Balanced XLR main mix, Booth and Aux Outputs on ¼" TRS Jacks, record output on RCA, and switchable Aux Return or Master Insert for full FX or Outboard integration.

The build quality is exemplary, with a Cerakoted and silkscreened front panel, machined from solid aluminium plate, high quality aluminium control knobs, a rugged 1.2mm Zintec chassis, and long-life steel shaft potentiometers and rugged switches throughout. Internally the mixer is fully modular with all PCBs mounted 90° to the front panel to prevent pooling in the event of a liquid spill and minimise audio crosstalk.

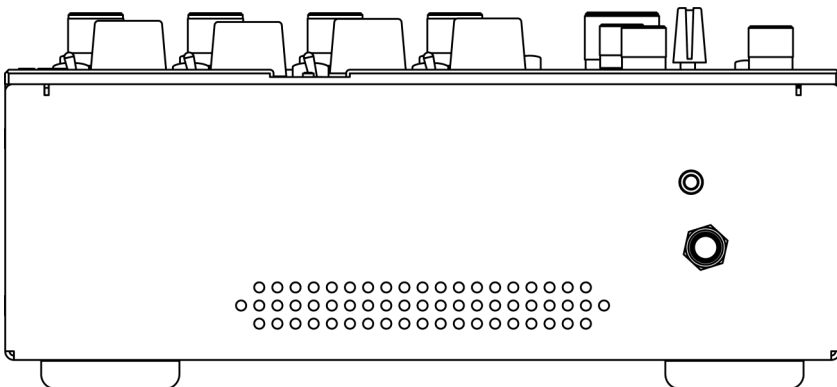
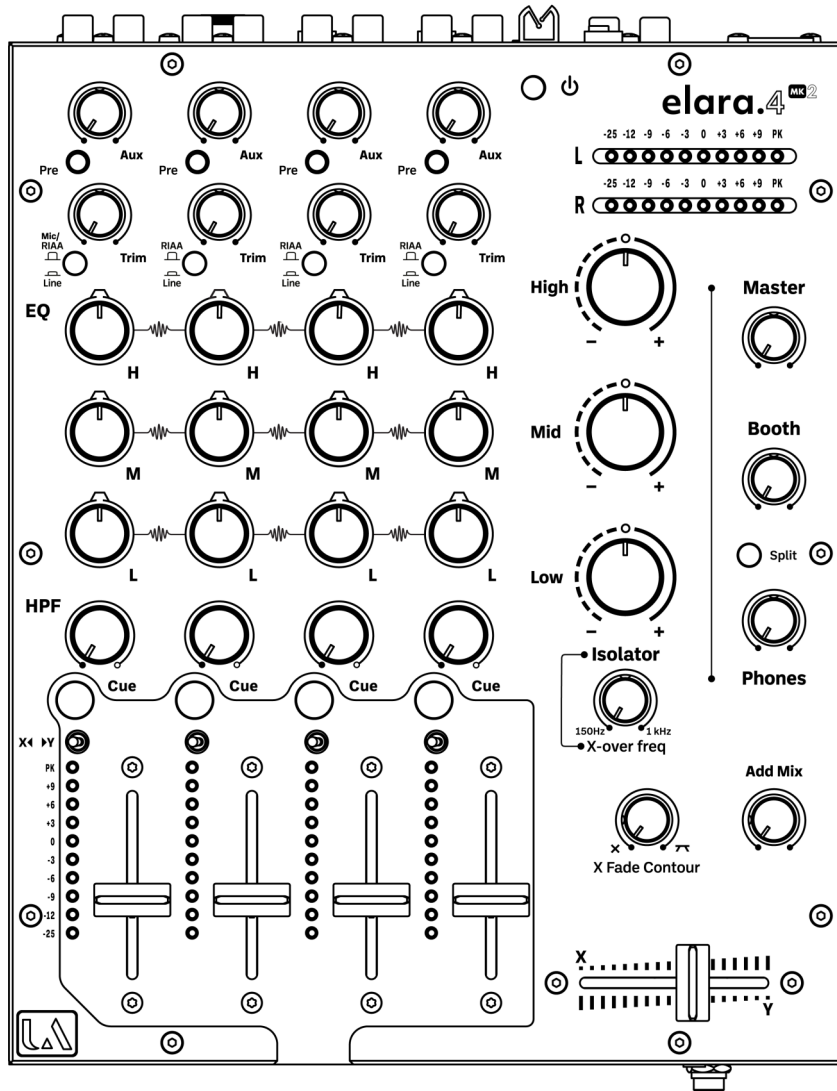
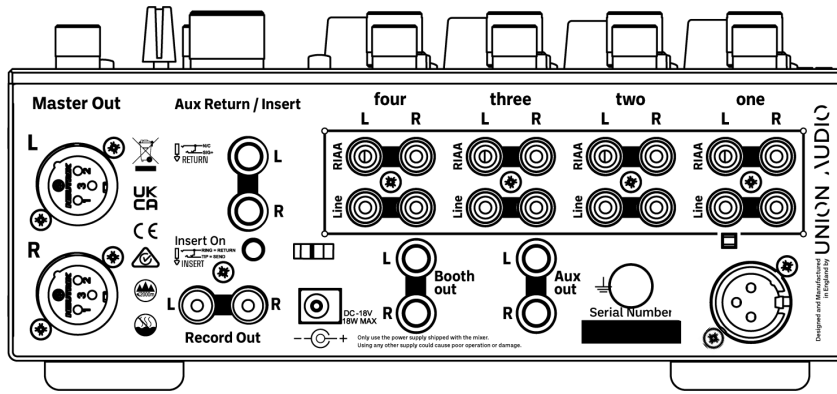

Input Channel Controls

Elara 4 MK2 has four audio channels, each with preamp stages and dual stereo inputs. All Channels feature Line and an RIAA inputs, with Channel One also featuring a MIC input, switchable from the Rear Panel.



Aux

Aux – The Auxiliary Send controls the channel signal level sent to the Aux Output, primarily for use with external effects or audio processors.



Pre

Pre – The auxiliary send can be configured as either pre-fader (down) or post-fader (up), determining where in the signal path the send is sourced from, and how it interacts with the channel's fader level. Pre-fader sends are useful when you need to send a constant signal for monitoring or external processing, while post-fader sends are beneficial for adding effects relative to the channel's level in the main mix, delays reverbs, etc.



Trim

Trim – Controls the level of the input signal from fully OFF to a maximum gain of +10dBu. Use in conjunction with the Channel VU Meter to set the optimum signal level, with the average lighting the Blue 0VU LED and the peaks just lighting the White +3VU LED.

RIAA/Line select – The Input selector switch sets the input source for each channel.

The RIAA inputs are for connection to a moving magnet cartridge for vinyl replay.



RIAA is selected when the button is out and not illuminated.

The line inputs are for connection to Line-Level devices such as CD and Media Players.

Input Channel Controls Continued

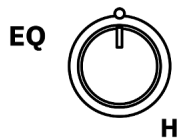

EQ – The channel EQ adjusts the gain or attenuation at three specific frequency ranges. The Low pot set at 200Hz, mid at 1.1kHz and high at 2kHz. Each control gives approximately -20dB of cut and +6dB of boost.



HPF – The high-pass filter (HPF) attenuates all frequencies below the cut-off point, with a swept frequency range from 18Hz to 1.8kHz. It features Variable-Q and a two-pole response.

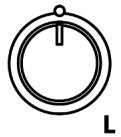

The Variable-Q automatically increases the filter's resonance at higher cut-off frequencies for that classic analogue filter sound, without the danger of excessively boosting low frequencies.



Cue – The Cue button illuminates red when active, and routes the pre-fader channel signal to the headphone monitor for auditioning. The button has a toggle function and will turn on/off with each press. Each channel cue is independent and will not be overridden when pressing other channel cue buttons.

Meter – Each channel has its own associated 10 bar LED meter. The meter is peak reading and is scaled from -25VU to PK (+12VU).

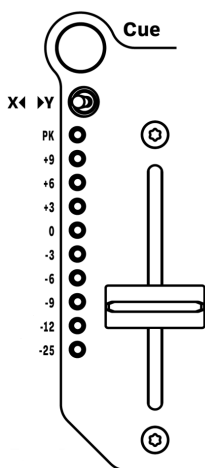

For Optimal signal-to-noise ratio (SNR) with minimum distortion (THD) set the channel audio level so that the blue 0VU LED is illuminated, and the signal peaks are just lighting the white +3VU LED. Adjustment is set using the Channel Trim (see page 9).

Fader – The channel faders provide smooth mix transitions between the different audio sources. They are not intended to be used to set the channel level fed to the main Mix Buss - use the Channel Trim control for this.

Each fader has a range from Off, (down) to unity, (up), with a progressive linear law. There is no signal gain built into the channel fader, and for best dynamic range it should be operated fully up on any channel feeding into the mix. The 45mm faders are damped for precise level changes

Master Section

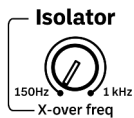
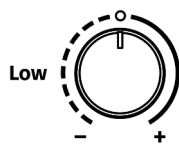
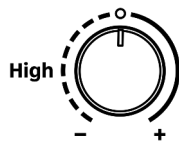

Master



Booth



Phones

EQ/Isolator – The EQ/isolator with variable crossover control is designed to complement the channel EQ and allow for some highly creative sound sculpturing. It has a wide “Q” and can be swept from 150Hz to 1kHz (Low-Mid crossover point) by adjusting the “X-over freq” control. The EQ/Isolator offers full signal cut and +6dB of boost over three frequency bands, High, Mid, Low. Like an EQ the Isolator can be used for audio frequency correction, however, unlike an EQ the Isolator completely attenuates the signal when the knobs are fully anti-clockwise. With the knob pointers in the centre position the frequency response is flat.

Master – The Master Output level is adjusted from fully off to +10dBu gain. For best signal to noise ratio (SNR) it is recommended operating the mixer with the knob pointer at “12 o'clock” or above. If this results in excessive volume then reduce the gain on the connected power amplifiers

Booth – Adjusts the signal level of the Booth Outputs from off to +10dBu when rotated fully clockwise. For best signal to noise ratio (SNR), set the level with the pointer at or above the 12 o'clock position.

Phones – Adjusts the level of the headphone output. The elara.4 is fitted with a powerful headphone amplifier, optimised for use with headphones having an impedance between 33ohms to 170ohms. Headphones with impedances above or below the recommended impedance should be avoided, and in particular headphones with impedances below 33ohms could cause damage to the circuitry.



WARNING! Avoid operating the mixer with headphones at high volume or for extended periods of time as this can contribute to severe hearing loss!

Master Section Continued



Split

Split — When the Split Cue is active (button illuminated) the Cue signal is routed only to the left headphone when a channel Cue is On, while the main Mix is always routed to the right headphone.



Add Mix

Add Mix — Sets the amount of the Main Mix signal heard in the headphones when a Channel Cue is active. This is very useful when beatmatching .



X Fade Contour

X Fade Contour — The Crossfader Contour sets the fade curve of the crossfader from smooth for mixing, to a sharp cut for scratching.

Crossfader — The crossfader is used to fade between channels assigned to either the X or Y side of the crossfader.

Use the channel toggle switches to assign each channel to either the X or Y side of the crossfader, or OFF if the switch is in the centre position.

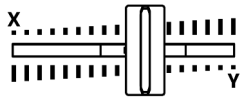

Master Meters — The Master Meters display Mix Buss level on the left and right channels. The meter indication is not affected by the Main Mix level control.

When a Channel Cue is On the meters automatically switch to display the channel pre-fader signal level. When Split Cue is selected the Left Meter displays the Cue signal level while the Right Meter displays the Mix Level.

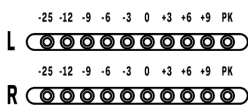

For the lowest distortion and the best dynamic range, operate the mixer with the meters reading between -3VU and $+6\text{VU}$. Avoid operating the mixer with the meter Red Peaks LEDs on.



Power Switch — Press to power ON the Mixer. The Button illuminates to indicate when the unit is powered on.

Rear Panel Input Connections

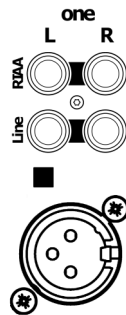

Channel One and MIC – The top row of RCA (Phono) connectors are designed for use with turntable magnetic cartridges and incorporate RIAA (Record Industry Association of America) equalisation. Do not connect line-level sources to these inputs as it could cause damage to the sensitive circuitry.

The lower row of RCA connectors are for Line level signals within the range of +26dBu to -10dBu.

Channel One also incorporates a Microphone Input, this is activated by pressing in the recessed Button on the Rear Panel when the Channel Input is set to RIAA. The Microphone input is designed to work with Dynamic Moving Coil microphones only.

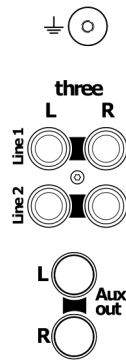

Earth terminal – This is for grounding the Turntables to reduce ground hum. Unscrew the knurled post and connect the turntables ground fork terminal between the mixer chassis and the post, then retighten.

Channel Two to Four – Channels Two to Four have Line and RIAA inputs .

Aux out – The Auxiliary Output is via 1/4" TRS Jack sockets following the standard convention of Tip Hot, Ring Cold, and Sleeve Ground. The nominal output level is 0dBu.

Aux Return / Insert

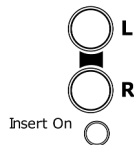

Aux Return / Insert – The Auxiliary Return is via a pair of 1/4" TRS Jack sockets following the standard convention of Tip Hot, Ring Signal Ground, and Sleeve Chassis Ground. The nominal input level is 0dBu.

Pressing the "Insert ON" button converts the Return Jack sockets to a Master Insert and follows the standard convention of Tip = Send, Ring = Return, Sleeve ground. The connector's normalising contacts by-pass the insert when nothing is plugged in.

Any External Processor should have a nominal operating level between -2dBu to +18dBu. Be aware that any external equipment plugged into these sockets will have an impact on audio fidelity, and it is strongly recommended to use studio grade equipment.



Record Out – The Record Output is via an RCA connector with a nominal level of 316mV, -10dBV (-8dBu) and is compatible with most 2-track recorders. The Record output is taken post Insert and will be affected by the Isolator EQ but not by the Master Level control.

Master Output Connections

Master Out

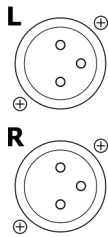

Master Out – The Master Output XLRs are electronically balanced, with Pin 2 hot (positive phase), Pin 3 cold (negative phase), and Pin 1 ground. When the Master Level control is fully clockwise, with the Meters reading -4VU the output level is approximately $+6\text{dBu}$.



Booth Out – The Booth Output is via a $\frac{1}{4}$ " TRS jacks. When the Booth level control is fully clockwise, with the Meters reading 0VU the output level is approximately $+12\text{dBu}$.



Phones Out – The headphones output is fitted with both $\frac{1}{4}$ " TRS and $\frac{1}{8}$ " TRS jack sockets, located on the front edge of the mixer.



elara.4^{MK2} APPLICATION GUIDE

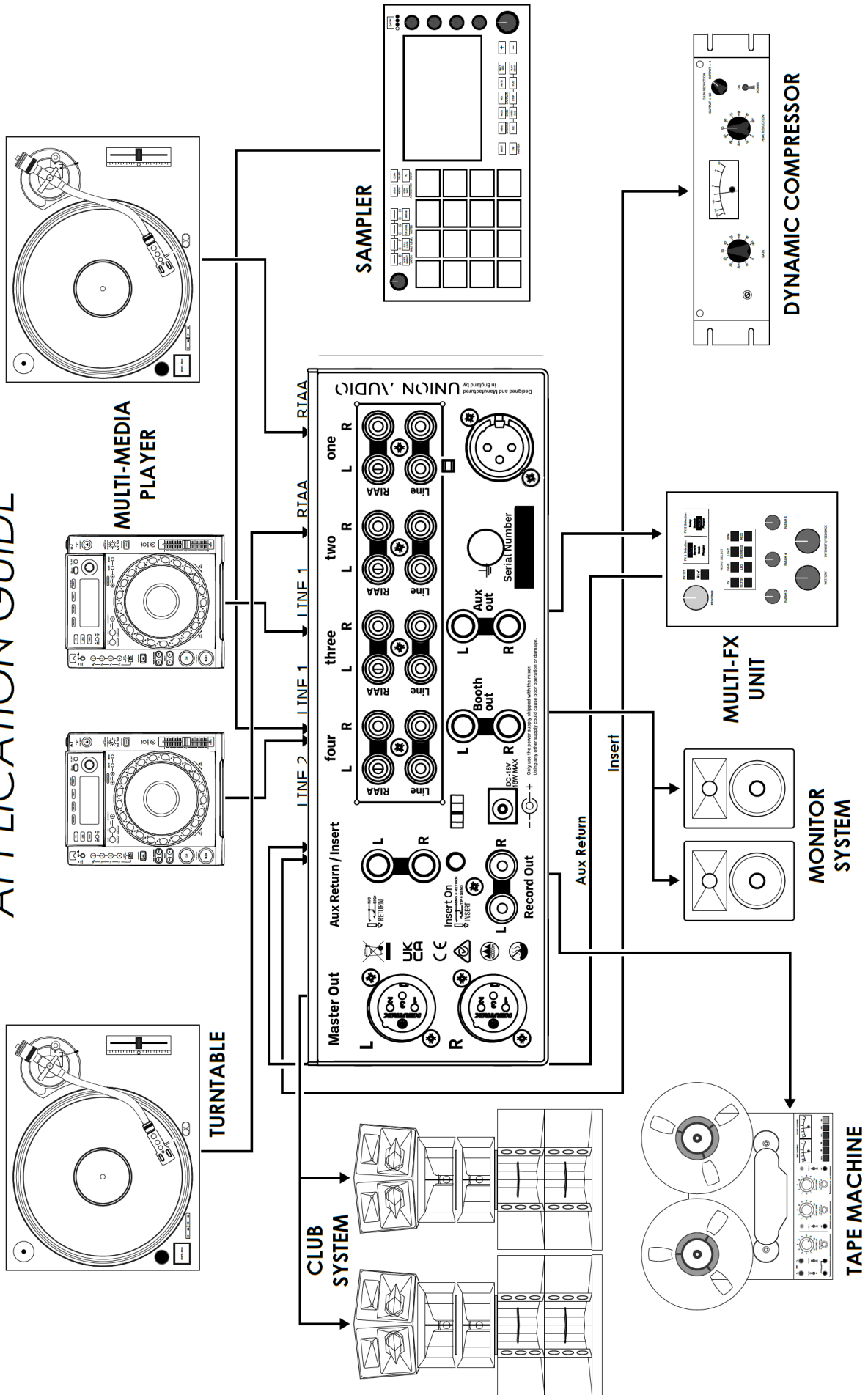

elara.4 ^{MK2} BLOCK DIAGRAM

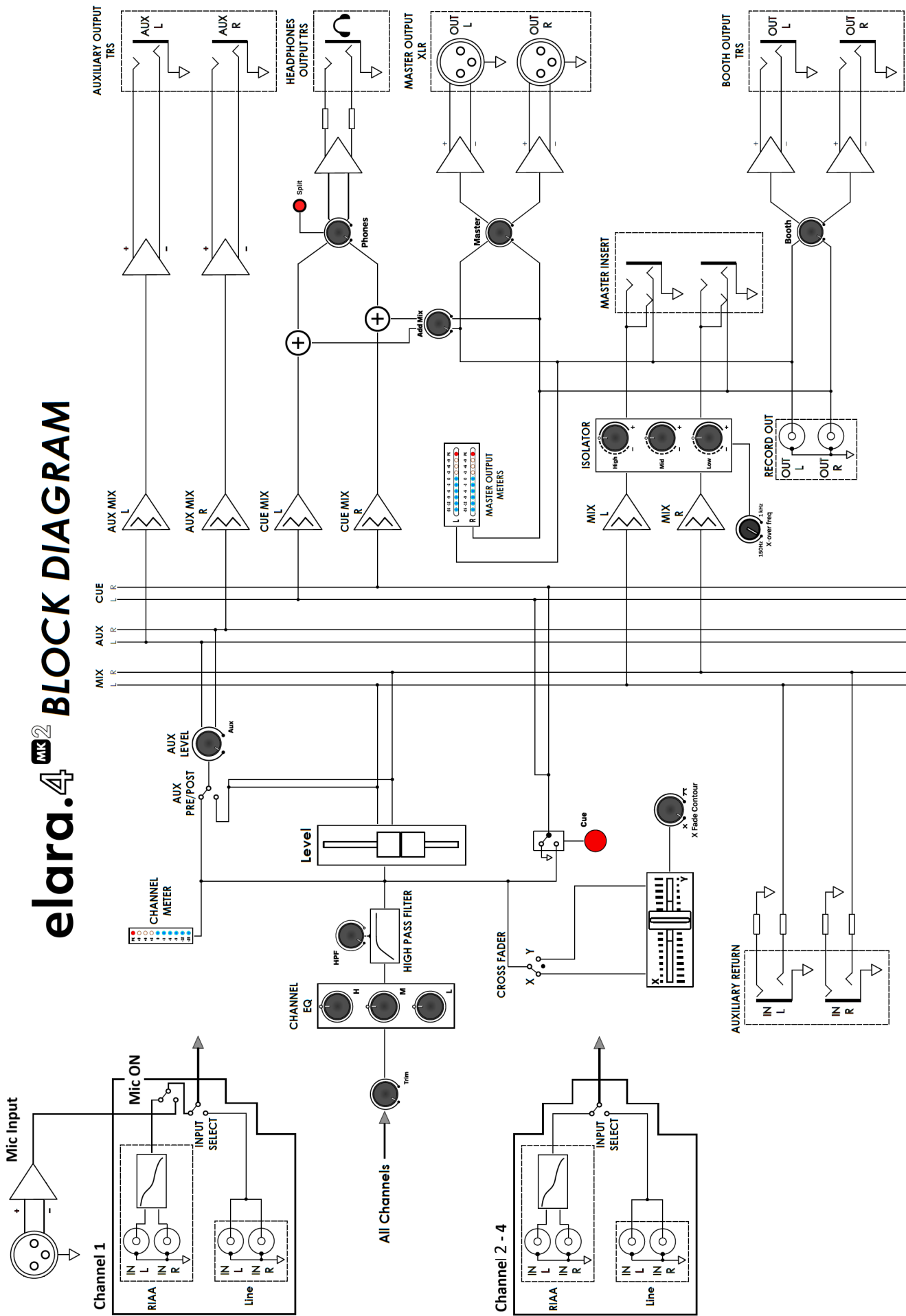

Specification

Distortion plus Noise (THD+N) un-weighted

0dBu, 20Hz to 20kHz, Line In to Mix Out +4dBu 0.01%

Frequency Response

Line in to Mix Out +/-0.5dB 30Hz - 30kHz

RIAA Accuracy +/-0.5dB 20Hz to 20kHz

Shutoff and Crosstalk

Fader Shutoff > -80dB

L/R Crosstalk Line in to Mix Out 1kHz <-75dB

Noise 22Hz to 22kHz Un-Weighted

Residual Mix Output noise <-98dBu

Line In to Mix Out Unity <-81dBu

Maximum Output Level Mix Out 0.5% THD +27dBu

Dynamic Range 108dB

EQ and Filter Frequency

Channel High-Pass Filter Fully Clockwise -3dB/1800Hz

Iso/EQ MID Frequency Adjustment Range 150Hz to 1kHz

Channel 3 Band EQ 200Hz, 1100Hz, 2000Hz

Headphone Amplifier

Maximum output level 900mW RMS - 36 ohms

Power Supply

Type External SMPSU

Mains Voltage range 90-260VAC

Output 18V DC 30W

Efficiency LEVEL VI

Dimensions

Dimensions

Mixer

Height	283mm
Width	230mm
Depth	88mm
Weight	3.25kg

Packed Dimensions

Size L x W x H	37cm x 36cm x 19cm
Weight	4.85kg (11lb)

